

(19)



(11)

EP 3 984 826 B1

(12)

EUROPEAN PATENT SPECIFICATION

(45) Date of publication and mention of the grant of the patent:
29.04.2026 Bulletin 2026/18

(51) International Patent Classification (IPC):
H04N 23/51 (2023.01) H04N 23/57 (2023.01)
B60R 11/04 (2006.01) B60R 1/00 (2022.01)

(21) Application number: **20202497.2**

(52) Cooperative Patent Classification (CPC):
H04N 23/57; H04N 23/51

(22) Date of filing: **19.10.2020**

(54) **DRIVER MONITORING SYSTEM AND METHOD FOR MANUFACTURING A DRIVER MONITORING SYSTEM**

FÄHRERÜBERWACHUNGSSYSTEM UND VERFAHREN ZUR HERSTELLUNG EINES FÄHRERÜBERWACHUNGSSYSTEMS

SYSTÈME DE SURVEILLANCE DE CONDUCTEUR ET PROCÉDÉ DE FABRICATION D'UN SYSTÈME DE SURVEILLANCE DE CONDUCTEUR

(84) Designated Contracting States:
AL AT BE BG CH CY CZ DE DK EE ES FI FR GB GR HR HU IE IS IT LI LT LU LV MC MK MT NL NO PL PT RO RS SE SI SK SM TR

• **HOMUTESCU, Adrian**
700051 Iasi (RO)

(43) Date of publication of application:
20.04.2022 Bulletin 2022/16

(74) Representative: **Reichert & Lindner**
Partnerschaft Patentanwälte
Prüfeninger Straße 21
93049 Regensburg (DE)

(73) Proprietor: **Magna Electronics Sweden AB**
447 37 Vårgårda (SE)

(56) References cited:
EP-A1- 3 531 685 EP-A2- 1 469 656
CN-U- 203 327 131 CN-U- 210 016 543
US-A1- 2020 307 825

(72) Inventors:
 • **PADURARIU, Catalin**
700051 Iasi (RO)

EP 3 984 826 B1

Note: Within nine months of the publication of the mention of the grant of the European patent in the European Patent Bulletin, any person may give notice to the European Patent Office of opposition to that patent, in accordance with the Implementing Regulations. Notice of opposition shall not be deemed to have been filed until the opposition fee has been paid. (Art. 99(1) European Patent Convention).

Description

FIELD OF THE INVENTION

[0001] The invention relates to a system for looking at a driver. Especially, the system comprises at least a camera sub-assembly which is positioned in an outer housing. The optical axis of the camera sub-assembly is pointing to an outside of the outer housing. The outer housing is defined by a housing cover and a housing base.

[0002] Furthermore invention relates to a method for manufacturing a system. The system to be mounted at or close to a windshield of a motor vehicle, looking at a driver of the motor vehicle, comprises at least a camera sub-assembly positioned in an outer housing, so that its optical axis is pointing to an outside of the outer housing. The outer housing is defined by a housing cover and a housing base.

DESCRIPTION OF THE BACKGROUND ART

[0003] International patent application WO 2019/164724 A1 discloses a camera module assembly. An outer housing for the camera module comprises a front shell with a window and a rear shell. The camera core includes a lens assembly, a sensor assembly, and a sensor housing. The sensor assembly is disposed within the sensor housing, and the sensor housing is fixed to the lens assembly.

[0004] International patent application WO 2018/219951 A1 relates to a camera module for a motor vehicle. The camera module is used for driver monitoring in the passenger compartment. The camera module has at least one printed circuit board and a shield for enclosing said printed circuit board. The shield comprises at least a first shielding part and a second shielding part.

[0005] U.S. patent application US 2019/208091 A1 discloses a camera module for a vehicular vision system. The camera module includes a metal front housing, a lens holder and a metal rear housing. The front housing houses a printed circuit board having an imager disposed thereat. The lens holder is attached at a front portion of the housing so that a lens assembly is optically aligned with the imager.

[0006] U.S. patent application US 2018/222402 A1 discloses a camera housing portion which has an imaging sensor at a base portion of the camera housing portion. A lens system is at a first portion of the camera housing portion. A first circuit board is provided that includes circuitry associated with the imaging sensor, which is disposed at a second circuit board that is in board-to-board electrical connection with the first circuit board. The camera housing portion and a connector portion are joined together to encase the first and second circuit boards.

[0007] Chinese utility model CN 203327131 U discloses a vehicle-mounted street lamp type camera.

The camera has a spherical camera body. The camera body sits in a through hole of a pedestal and is covered by a rear cover which covers the pedestal. The spherical camera body can be rotatably installed on the rotation through hole of the pedestal. Through rotating of a locking bolt along a positive direction, chucking of the clamping support to the spherical camera body can be released.

[0008] Chinese utility model CN 210016543 U discloses an intelligent network camera device with an automatic plug. The device comprises an upper shell, a lower shell and a control assembly. The plug camera device of the utility model combines a plurality of functions such as camera shooting, voice bidirectional intercom, one-key calling, wireless transmission, storage and the like, thereby improving user experience. The camera is rotatable; the socket is arranged and can be flexibly used. The art disclosed here has nothing to do with camera system mounted in a vehicle.

[0009] European Patent Application EP 3 531 685 A1 discloses an image capturing apparatus, which includes a camera unit, a substrate unit arranged near the camera unit, a substantially sphere-shaped dome cover configured to cover the camera unit. A housing is configured to support the dome cover and to cover the substrate unit.

The dome cover is arranged eccentric to the housing, and wherein the external recording unit is arranged between the camera unit and the substrate unit. The art disclosed here has nothing to do with camera system mounted in a vehicle. European Patent Application EP 1 469 656 A2 discloses a mobile phone having a rotational camera lens housing. The mobile phone includes a first housing and a second housing. A hinge housing rotatably connects the first housing to the second housing, a rotational camera lens housing is contained in the hinge housing, and an exposurer in the hinge housing exposes a camera lens at least twice according to the rotation of the camera lens housing. The art disclosed here has nothing to do with camera system mounted in a vehicle.

[0010] US Patent Application US 2020/0307825 discloses camera module for surveillance of a passenger cabin of an aircraft. A camera of the camera module includes a camera housing having a mounting portion with a spherically curved outer surface. The camera housing is mounted by the mounting portion in the mounting structure to be rotatable or pivotable about at least two axes. A locking device is provided for locking the camera housing relative to the mounting structure. The locking device can be embodied by way of a screwed retaining ring, which causes a pretension of the mounting piece in the direction of the bearing portion, by springs or pins.

[0011] In general, vision cameras are more and more present in vehicles. They are used for scanning the environment of the vehicle and also the driver and passengers, sending the data to an ECU (electronic control unit) that is processing the data and sending out warnings to the driver or acting on the vehicle brakes. The most advance vision cameras use two cameras working in stereo configuration to output also the distance. An algo-

rithm is used and the ECU receives the distance to the object.

[0012] In existing prior art systems, the vision camera is calibrated during installation with regards to relative positioning imager sensor on the. The vision camera is fixed by a fixing glue, which fixes camera housing to printed circuit board after curing. The vision camera and the printed circuit board are temporarily fixed together by an external fixture until glue is cured. The sub-assembly of the camera and the printed circuit board are afterwards fixed to the housing.

[0013] With different car lines, the required position of an infrared module in the vehicle may differ from car line to car line, in order to keep focus on the driver. In order to function properly, the installation position of the infrared module, included in the driver monitoring system, is made at different angles as well as inside the electronic control unit (ECU) of the driver monitoring system. This is due to the necessity of mounting of the driver monitoring system's ECU in different positions in the vehicle, also if it is mounted on vehicles with steering on the left or right side, but not limited to it. This brings about a diversity of housing and cover parts, so that similar projects do not share the same housings and covers. It may be that ECUs with identical functions and printed circuit boards are different in construction due to that. Consequently, the development, validation and manufacturing cost is therefore high for such a driver monitoring system.

SUMMARY OF THE INVENTION

[0014] It is an object of the present invention to provide a system which can be used for a wide variety of car lines. Additionally, the inventive system should save costs and reduce the variety of parts of the system.

[0015] The above object is achieved by a system which comprises the features of claim 1.

[0016] It is a further object of the present invention to provide a method for manufacturing a system which allows a safe and secure orientation of an optical axis of a vision camera of the driver monitoring system and can be used for a wide variety of car lines. Additionally, the inventive method should save costs and reduce the variety of parts of the system.

[0017] The above object is achieved by a method for manufacturing a system which comprises the features of claim 6.

[0018] According to the invention a system is mounted at or close to a windshield of a motor vehicle, looking at a driver of the motor vehicle. The system comprises at least a camera sub-assembly positioned in an outer housing so that its optical axis is pointing to an outside of the outer housing, wherein the outer housing is defined by a housing cover and a housing base. A housing part for the camera sub-assembly has a spherical outer topology. A mounting structure, defined by a retainer ring, is positioned at least in relation to a receptacle of the housing base. A spheroidal inner topology of the retainer ring

matches the spherical outer contour of the housing part of the camera sub-assembly, wherein the mounting structure allows an angular adjustment of the optical axis of the camera sub-assembly. A glue is applied at the boundary between the housing part of the camera sub-assembly and the retainer ring to fix a spatial orientation of the optical axis.

[0019] The advantage of the system is it can be used with different car lines. Furthermore, the system can reflect as well the various needs of the drivers. With the present invention the diversity of housing parts and cover parts is reduced and the development, validation and manufacturing cost are reduced as well, because the inventive embodiment of the system can serve multiple carlines.

[0020] According to the present invention, the mounting structure is a retainer ring with a spheroidal inner topology. The spheroidal inner topology of the retainer ring matches the spherical outer contour of the housing part of the camera sub-assembly.

[0021] The advantage is that the orientation of the optical axis of the camera sub-assembly can be set before the camera sub-assembly is mounted in the outer housing (the same outer housing for various car lines or needs). Additionally, the match of the spheroidal inner topology of the retainer ring and the spherical outer contour of the housing part of the camera sub-assembly allow a rotation of the housing part of camera sub-assembly. Consequently, multiple relative positions of the retainer ring and the camera sub-assembly are possible, which is due to the nature of the spherical joint.

[0022] According to a further embodiment of the present invention the spherical inner topology of the retainer ring is centred in a middle plane of the retainer ring. Consequently, the spherical inner topology of the retainer ring matches the spherical outer contour of the housing part of the camera sub-assembly at a position of a maximal diameter of the housing part of the camera sub-assembly. The maximal diameter is perpendicular to the optical axis.

[0023] The advantage of this embodiment is that as well multiple relative positions of the retainer ring and the camera sub-assembly are possible, which is due to the nature of the spherical joint. Furthermore, this embodiment achieves an additional robustness against a failure case that the camera sub-assembly could fall out of the lock with the retainer ring or lose the relative position to it.

[0024] According to the invention the set spatial orientation of the optical axes is fixed by a glue. The glue is provided such that a relative movement of the retainer ring and the spherical outer contour of the housing part of the camera sub-assembly is blocked. The glue is applied in at least one window of the retainer ring.

[0025] The advantage of the cured glue is that it locks the position of the housing part of the camera sub-assembly relative to the retainer ring and thereby fixes the orientation of the optical axis for further mounting.

[0026] According to an embodiment of the invention,

the retainer ring is centred with its spherical inner topology of in a middle plane of the retainer ring and the retainer ring matches the spherical outer contour of the housing part of the camera sub-assembly. After spatial orientation of the optical axis the retainer ring is in tight fit contact with the housing part of the camera sub-assembly.

[0027] The advantage of the embodiment is that the spatial orientation of the optical axis can be maintained without a glue. In order to position the optical axis of the camera sub-assembly in the nominal position, the retainer ring warmed up so the interference is reduced. After the camera sub-assembly is positioned in the retainer ring, it can be as well oriented to achieve the final angular orientation of the optical axis. Immediately afterwards, the retainer ring is to be cooled down by itself or via a special operation (blowing of cold air over the retainer ring etc.) and the tight fit is achieved. Unintended rotation of the camera sub-assembly in the field is prevented, therefore. Ideally, the housing part of the camera sub-assembly and the retainer ring shall be manufactured out of metal. The same material is needed so that dilation and contraction of fit maintains clamping.

[0028] According to an embodiment of the invention, the mounting structure is defined by an indexing pivot and a spherical topology of the housing cover. The indexing pivot is positioned in the receptacle of the housing base and a pivot shaft of the indexing pivot is sitting in the housing base.

[0029] According to a further unclaimed embodiment the indexing pivot has a plurality of indexing teeth, which are in contact with set of indexing holes in the spherical outer topology of the housing part of the camera sub-assembly. The spherical topology of the housing cover is in form fitting contact with the spherical outer topology of the housing part of the camera sub-assembly. Additionally, the indexing pivot has indexing fins at a bottom side. The indexing fins interact with grooves of an indexing and sitting recess, which is positioned on the receptacle of the housing base.

[0030] The advantage of the embodiment is that with the indexing pivot an angular adjustment solution can be glue free for a spherical camera for a housing part of the camera sub-assembly. With the invention it is possible to accommodate multiple installation angles of the optical axis of the camera sub-assembly. There is no need of redesign and revalidate concepts when a new carline is imposing a different position of system inside the vehicle. The angular adjustment of field of view direction is possible at any moment, with a chosen Increment. There is no need of providing a glue or other fixation element in order to fix and maintain the orientation of the optical axis of the camera sub-assembly. The cost of development, validation and manufacturing new modules is reduced with the invention across a family of products serving multiple carlines. One single product type can be manufactured, which serves multiple carlines. A customer may simply adjust the field of view direction to the needed angle, without effort or intervention of manufacturer.

[0031] A method for manufacturing a system is characterized in that a housing part of the camera sub-assembly is positioned in cooperation with at least part of a mounting structure in a receptacle of the housing base.

The mounting of the housing cover to the housing base holds the housing part of the camera sub-assembly held by the outer housing cover. The camera sub-assembly is positioned in the outer housing so that its optical axis is pointing to an outside of the outer housing

[0032] The mounting structure is a retainer ring which surrounds the spherical outer topology of the housing part of the camera sub-assembly. An orientation of the optical axis of the camera sub-assembly is adjusted by a gripping tool prior to positioning the retainer ring on the receptacle of the housing base. The adjusted orientation of the optical axis of the camera sub-assembly is maintained by a glue applied as a seam between the retainer ring and the spherical outer topology of the housing part and/or by a glue filled in at least one window of the retainer ring. According to a further embodiment the adjusted orientation of the optical axis of the camera sub-assembly is maintained by a tight fit contact of the retainer ring with the housing part of the camera sub-assembly after a spatial orientation of the optical axes.

[0033] The advantage of the above described embodiment is an angular adjustment concept for an optical axis of the camera sub-assembly, so that one concept of a system can be used in different types of vehicles. The cost of development, validation and manufacturing new modules of a system is reduced with the invention.

[0034] According to an unclaimed embodiment, the mounting structure is defined by a spherical topology of the housing cover and an indexing pivot, sitting in the receptacle of the housing base. An orientation of the optical axis of the camera sub-assembly is adjusted by a gripping tool after the spherical topology of the housing cover is in form fitting contact with the spherical outer topology of the housing part of the camera sub-assembly. An orientation of the optical axis of the camera sub-assembly is maintained in a first rotating direction by indexing teeth of the indexing pivot which get into contact with another set of indexing holes in the spherical outer topology of the housing part of the camera sub-assembly. An orientation of the optical axis of the camera sub-assembly is maintained in a second rotating direction by indexing fins of the indexing pivot, which get into contact with a set of indexing grooves of an indexing and sitting recess on the receptacle of the housing base.

[0035] The advantage of the above embodiment is that a re-adjustment of the orientation of the optical axis of the camera sub-assembly can be carried out in two directions at any moment. A scenario may be that an original equipment manufacturer has a stock of systems or electronic control units with camera, however different car lines are assembled. Same systems or electronic control units are taken from logistic and, during mounting on the vehicle assembly line, the angles are adjusted according to the particular angular position requirement of each car

line. If desired, the adjustment moment (torque) may be tuned so that change of angle may be done by hand by an operator, or the opposite is possible if desired. If desired, the screws close to the sandwich of the housing part of the camera sub-assembly and the mounting structure can bring additional clamping to the package.

BRIEF DESCRIPTION OF THE DRAWINGS

[0036] The numerous advantages of the disclosure may be better understood by those skilled in the art by reference to the accompanying figures in which:

Figure 1 is a schematic representation of the placement of a system camera according to an embodiment of the prior art.

Figure 2 is sliced view of an exemplary model of a state of the art vision camera.

Figure 3 is a perspective view of a state of the art housing of the vision camera and the printed circuit board.

Figure 4 is a sliced perspective view exemplary a state of the art module of the vision camera.

Figure 5 is a detailed view of a state of the art mounting of a camera a system.

Figure 6 is a perspective view system with a vision camera module and an infrared module according to the prior art.

Figures 7A to 7C are various views of one embodiment of the camera sub-assembly.

Figures 8A to 8C are various views of the camera sub-assembly with a mounting structure for adjusting various orientations of the camera sub-assembly.

Figure 9A to 9C are various views of an embodiment of the mounting structure in the form of a retainer ring.

Figure 10 is a partial sectional view of a portion of the housing base with the receptacle for the camera sub-assembly.

Figure 11A to 11E show the stages of mounting and orienting the camera sub-assembly with respect to the retainer ring.

Figure 12 is a perspective view of the housing base with the mounted camera sub-assembly.

Figure 13 is a sectional and enlarged view of the

camera sub-assembly mounted to the housing base.

Figure 14 is top view of the housing base wherein the oriented camera sub-assembly is mounted to the housing base with the retainer ring.

Figure 15 is an enlarged view of the area marked with the rectangle R in Fig. 14.

Figure 16 is an enlarged and partial side view of the housing base with the mounted camera sub-assembly.

Figure 17 is a front view of the housing base with the mounted camera sub-assembly showing an example of extreme adjustment of the camera sub-assembly about two axes.

Figure 18 is a perspective view of the outer housing, which is composed of a housing base and a housing cover.

Figure 19A-19B show various views of a further embodiment of the retainer ring.

Figure 20A-20B show the stages of mounting the camera sub-assembly and the retainer ring as shown in the embodiment of Figs. 19A and 19B.

Figure 21 is an enlarged sectional view of the camera sub-assembly in the nominal position mounted according to the steps shown in Figure 20A-20B.

Figure 22 is a side view of the camera sub-assembly, showing the possible orientations.

Figure 23A-23B are various views of a further embodiment of the camera sub-assembly.

Figure 24 is a schematic view of embodiment of a mounting structure for a camera sub-assembly in an outer housing of the system.

Figure 25 is an enlarged view of the area marked with A of Fig. 24.

Figure 26 is a schematic top view of the indexing pivot of the mounting structure of Fig. 24.

Figure 27 is a schematic top view of a rotational area of the mounting structure of Fig. 24.

Figure 28 is a schematic representation of the angular adjustment camera sub-assembly with the mounting structure of Fig. 24.

DETAILED DESCRIPTION

[0037] In the ensuing description, numerous specific details are provided to enable maximum understanding of the embodiments that are provided by way of example. The embodiments may be implemented with or without specific details, or else with other methods, components, materials, etc. In other circumstances, well-known structures, materials, or operations are not illustrated or described in detail so that various aspects of the embodiments will not be obscured. Reference in the course of the present description to "an embodiment" or "one embodiment" means that a particular structure, peculiarity, or characteristic described in connection with its implementation is comprised in at least one embodiment. Hence, phrases such as "in an embodiment" or "in one embodiment" that may recur in various points of the present description do not necessarily refer to one and the same embodiment. Furthermore, the particular structures, peculiarities, or characteristics may be combined in any convenient way in one or more embodiments

[0038] Same reference numerals refer to same elements or elements of similar function throughout the various figures. Furthermore, only reference numerals necessary for the description of the respective figure are shown in the figures. The shown embodiments represent only examples of how the invention can be carried out. This should not be construed as a limitation of the invention.

[0039] Fig. 1 shows the arrangement of a system 1 inside a motor vehicle 2 according to an embodiment of the prior art. The system 1 is mounted at or close to a windshield 3 of the motor vehicle 2, so that at least one vision device 10 (see Fig. 2) of the system 1 is looking at a driver 5 of the motor vehicle 2. Especially, a lens 4 of the vision device 10, which is, for example, a vision camera 11, is pointing at the driver 5.

[0040] Fig. 2 is sliced view of an exemplary model of a state of the art vision camera 100. The vision camera 100 is calibrated during installation with regards to relative positioning an imager sensor 102 on a printed circuit board 103. The vision camera 100 is fixed by a fixing glue 105, which fixes camera housing 101 to the printed circuit board 103 after curing. The vision camera 100 and the printed circuit board 103 are temporarily fixed together by external fixture (not shown) until the fixing glue 105 is cured. The assembly of the vision camera 100 and the printed circuit board 103 is afterwards fixed to the camera housing 101. The camera barrel 106 and the printed circuit board 103 are seated by 3 spheres on the camera on prismatic grooves (not shown) on the camera housing 101. A retainer ring 107 is slipped over the lens barrel 106 with rubber sector being compressed between the camera housing 101 and vision camera 10, from the other side. The retainer ring 107 is made from flexible plastic and rubber.

[0041] Fig. 3 is a perspective view of a state of the art housing part 110 of the vision camera 100 and the printed

circuit board (not shown here).

[0042] Fig. 4 is an exemplary sliced perspective view of a state of the art module of the vision camera 100. The printed circuit board 103 is attached with a fixing glue 105 to the camera housing 101.

[0043] Fig. 5 is a detailed view of a state of the art mounting of a vision camera 100 to an outer housing 7 of a system 1. The printed circuit board 103 is attached to the camera housing 101. The vision camera 100 is mounted in the outer housing 101, so that the optical axis 11 of the vision camera 100 is arranged at an angle in relation with the driver of the vehicle 2.

[0044] Fig. 6 is a perspective view of a system 1 according to an embodiment of the prior art. The system 1 has a vision camera 100 and an infrared module 12. The vision camera 100 defines a camera window (not shown). The infrared module 12 defines an IR window (not shown). The infrared module 12 of the prior art system 1 has two infrared diodes 17. The number of diodes 17 should not be regarded as a limitation. The system 1 has an outer housing 7 which is composed of a housing cover 8 and a housing base 9. The housing base 9 has at least one mounting ear 6 for fixing the system 1 in the vehicle 2.

[0045] The system 1 is positioned inside the vehicle 2 in such a manner that the driver's 5 face is predictably in the middle of the vision camera's 100 field of view. The infrared module 12 is positioned in the vicinity of the vision camera 100 so that if natural light is insufficient, the driver is lit in a non-distracting manner by infrared light. The infrared diodes 17 are populated on a printed circuit board which is further attached, for example with thermal paste, to the cooling dome 14. According to the prior art, the cooling dome 14 is made of metal.

[0046] Figs. 7A to 7C are various views of one embodiment of the camera sub-assembly 10. The camera sub-assembly 10 comprises a lens barrel 106 which is surrounded by a housing part 20 that has a spherical outer topology 21 (or spheroidal topology). The housing part 20 of the camera sub-assembly 10 has formed a gripping base 22, which is utilized for gripping camera sub-assembly 10 to achieve a desired orientation of an optical axis 11. A printed circuit board 103 with an image sensor 102 is attached to the gripping base 22. The lens barrel 106 defines the optical axis 11 which is perpendicular on the image sensor 102.

[0047] Figs. 8A to 8C show various views of the camera sub-assembly 10 with a mounting structure 30 for adjusting and fixing various orientations of the optical axis 11 of the camera sub-assembly 10. In the embodiment shown here the mounting structure 30 is a retainer ring 31. Fig. 8A shows the situation that the spherical outer topology 21 of the housing part 20 is surrounded by the retainer ring 31. The optical axis 11 of the camera sub-assembly 10 is parallel to an axis of the cartesian coordinate system (exemplary the optical axis 11 is parallel to the Z-axis of the coordinate system). Fig. 8B shows the situation that the optical axis 11 of the camera sub-assembly 10 is tilted by an angle α in a plane of the cartesian

coordinate system (exemplary the optical axis 11 is tilted in the X/Z-plane of the coordinate system). Fig. 8C shows the situation that the optical axis 11 of the camera sub-assembly 10 is tilted by an angle β in a plane of the cartesian coordinate system (exemplary the optical axis 11 is tilted in the Y/Z-plane of the coordinate system). The maximum tilt can be in a range of $-\alpha$ to $+\alpha$ or $-\beta$ to $+\beta$, wherein the maximum value of α and β is 20° .

[0048] Figs. 9A to 9C show various views of the retainer ring 31 which is used as the mounting structure 30 for the camera sub-assembly 10. The retainer ring 31 has formed a spheroidal inner topology 32. The spheroidal inner topology 32 of the retainer ring 31 matches the spherical outer contour 21 of the housing part 20 of the camera sub-assembly 10. The camera sub-assembly 10, when surrounded by the retainer ring 31 (see Figs. 8A-8C) can be set at a desired angle. The retainer ring 31 has two lugs 33 with centring holes 35. The centring holes 35 of the retainer ring 31 provide an exact seating of the camera sub-assembly 10 on the housing base 9 (see Fig. 10). Another, optional function of the retainer ring 31 is to facilitate access of glue 39 (see Fig. 11E) to the interface between the retainer ring 31 and the spherical outer contour 21 of the housing part 20 of the camera sub-assembly 10. Therefore, the embodiment of the retainer ring 31 shown here has two windows 34, which are used to apply the glue 39.

[0049] Fig. 10 is a partial sectional view of a portion of the housing base 9 with the receptacle 16 for the retainer ring 31 of the camera sub-assembly 10. A wall 9W of housing base 9 separated the receptacle from the inner portion 9I of housing base 9. In addition, the receptacle 16 for the retainer ring 31 has two guiding pins 18 help to locate the retainer ring 31 at the housing base 9. The guiding pins 18 reach into the centring holes 35 of the lugs 33 of the retainer ring 31 (see Fig. 9A-9C). As needed by application, the guiding pins 18 can be located on the housing cover 8, instead.

[0050] Figs. 11A to 11E provide an insight of the stages of mounting and orienting the camera sub-assembly 10 with respect to the retainer ring 31. In Fig. 11A the step of the mounting process is shown that the retainer ring 31 is fixed inside a jig 25. The jig 25 grasps the retainer ring 31 by the two lugs 33. In the next step as shown in Fig. 11B the housing part 20 of the camera sub-assembly 10 is gripped by a gripping tool 26 at the gripping base 22 of the housing part 20 of the camera sub-assembly 10. The housing part 20 is positioned in a nominal position wherein the optical axis 11 is perpendicular to the retainer ring 31. In the step as shown in Fig. 11C the housing part 20 of the camera sub-assembly 10 is rotated to the angle or angles imposed by the application. The gripping tool 26 is still in contact with the at the gripping base 22 and the jig 25 still holds the retainer ring 31. As a result of the rotation 29 the housing part 20 is positioned such that the optical axis 11 is angled with respect to the retainer ring 31. The cooperation of the spherical outer topology 21 of the housing part 20 of the

camera sub-assembly 10 and the spheroidal inner topology 32 (see Fig. 9A) of the retainer ring 31 allow the free rotation 29. Fig. 11D shows the process step wherein a glue 39 is applied at the boundary between the housing part 20 of the camera sub-assembly 10 and the retainer ring 31. The gripping tool 26 and the jig 25 are still active. Preferably, the glue 39 is applied as a seam 38 at the boundary between the retainer ring 31 and the housing part 20 of the camera sub-assembly 10. Fig. 11E shows an alternate or additional step. Here, the glue 39 is filled in at least one window 34 of the retainer ring 31. The gripping tool 26 and the jig 25 are still active. After glue 39 is cured, the gripping tool 26 and the jig 25 grippers are removed and the camera sub-assembly 10 is ready for mounting.

[0051] A perspective view of the housing base 9 with the camera sub-assembly 10 mounted in the receptacle 16 of the housing base 9, is shown in Fig. 12. Here the mounting structure 30 is the retainer ring 31 which holds the oriented and fixed camera sub-assembly 10. A preferred, cost effective solution, is to clamp the camera sub-assembly 10 with dedicated guiding pins 18 at the housing base 9. The guiding pins 18 reach into the centring holes 35 see Fig. 9C) of the retainer ring 31 lugs 33.

[0052] Fig. 13 is a sectional and enlarged view of the camera sub-assembly 10 mounted to the housing base 9. The dedicated guiding pins 18 of the receptacle 16 of the housing base 9 reach into the centring holes 35 of the lugs 33 when the retainer ring 31 is pressed with a force 19, acting on the lugs 33, towards the receptacle 16. The retainer ring 31 and consequently the camera sub-assembly 10 is firmly mounted to the housing base 9.

[0053] This is an economically fixation method, wherein the retainer ring is fixed to the housing base, with no additional fixation part or operation. A guaranteed interference is needed between pins and holes, however one which does not lead to cracks in either part or need of high assembly forces. As interference would be variable with common part manufacturing precision, so will be the required assembly force, which may further mean a manufacturing challenge in making sure the final retainer ring position was reached.

[0054] It may as well be desirable to have no residual mechanical stress in the resulting assembly.

[0055] An alternate mounting method is "hot staking". Here the centring pins 18, likely together with entire housing base 9, are made of plastic. Then a centring, intermediate fit of pins (sometimes called stakes) on the centring holes 35 is possible. After the retainer ring 31 together with camera sub-assembly 10 has reached its final position on the housing base 9, a specific "hot staking head" is lowered on the tips of guiding pins 18 (centring pins) and warms them up over to the point of slight melting. The flowing material is pushed down so that a "rivet head" is created on top of lugs 33, thus locking the camera sub-assembly 10 and the housing base 9 together.

[0056] An alternate mounting method is "riveting". This

mounting method is used once the centring pins 18, likely together with entire housing base 9, are made of metal, for example aluminium, low-carbon steel or copper, or other ductile materials. In the beginning a centring and intermediate fit of pins 18 on centring holes is carried out. After the retainer ring 31 together with camera sub-assembly 10 have reached its final position on housing base 9, a specific press head (not shown) is lowered on the tips of centring pins 18. A specific stress with respect to the flow characteristic of a respective material is induced inside the tips of centring pins 18. The flowing material is pushed down so that a "rivet head" is created on top of lugs 33, thus locking the camera sub-assembly 10 and the housing base 9 together. The press may use a special die geometry to form the rivet head.

[0057] A further, alternate mounting method is a fixation by nuts, provided the tip of centring pins 18 are threaded. In the beginning a centring and intermediate fit of pins 18 on centring holes is carried out. After the retainer ring 31 together with camera sub-assembly 10 has reached its final position on housing base 9, a specific screwing machine (not shown) brings a nut to each threaded centring pin 18 and tightens it.

[0058] Fig. 14 is top view of the housing base 9 wherein the oriented camera sub-assembly 10 is mounted to the housing base 9 with the retainer ring 31. Fig. 15 is an enlarged view of the area marked with the rectangle R in Fig. 14. The retainer ring 31 with the camera sub-assembly 10 is attached to the housing base 9 with the guiding pins 18. The fixed orientation of the optical axis 11 of the camera sub-assembly 10 depends on the particular application of the system 1. The angle α of the optical axis 11 of camera sub-assembly 10 can be selected between -20° and $+20^\circ$ to the nominal position 15.

[0059] Fig. 16 is an enlarged and partial side view of the housing base 9 with the mounted camera sub-assembly 10. The retainer ring 31 with the camera sub-assembly 10 is attached to the housing base 9 with the guiding pins 18. The fixed orientation of the optical axis 11 of the camera sub-assembly 10 depends on the particular application of the system 1. The angle β of the optical axis 11 of camera sub-assembly 10 can be selected between -20° and $+20^\circ$ to the nominal position 15. Here the optical axis 11 is pointing down.

[0060] It is noted, that the glue 39 required for fixing the set orientation of the optical axis 11 is not shown in Figs. 14, 15 and 16.

[0061] Fig. 17 is a front view of the housing base 9 with the mounted camera sub-assembly showing an example of extreme adjustment of the camera sub assembly 10. As shown here, an aperture opening 13 of the camera sub assembly 10 is pointing to the upper left. This is only one of several adjustments of the camera sub-assembly 10 and should not be regarded as a limiting factor of the invention.

[0062] Fig. 18 is a perspective view of the outer housing 7 of the system 1. The outer housing 7 is composed of the housing base 9 and a housing cover 8. The system 1

holds the camera sub-assembly 10 and an infrared module 12. The outer housing 7 partly encloses the camera sub-assembly 10 and with the housing cover 8 and the housing base 9 the camera sub-assembly 10 is held in position in the system 1. The housing base 9 has at least one mounting ear 6 for fixing the system 1 in the vehicle 2 (see Fig. 1).

[0063] Figs. 19A and 19B show various views of a further embodiment of the retainer ring 31. The retainer ring 31 has the same general topology as the embodiment shown in Figs 9A to 9C. The retainer ring 31, shown here, has ability to retain camera sub-assembly 10 before glue 29 is applied. The spheroidal inner topology 32 of the retainer ring 31 is centred in the middle plane 36 of the retainer ring 31. As mentioned in the description with regard to Fig. 7A to 7C the housing part 20 of the camera sub-assembly 10 has a spherical topology 21 to match the spheroidal inner topology 32 (counter-topology) on the retainer ring 31.

[0064] Figs. 20A to 20B show the stages of mounting the camera sub-assembly 10 and the retainer ring 31 as shown in the embodiment of Figs. 19A and 19B. The housing part 20 of the camera sub-assembly 10 has the gripping base 22 which in contact with the gripping tool 26, which is used for gripping during the assembly of the camera sub-assembly 10 with the retainer ring 31. The jig 25 grasps the retainer ring 31 by the two lugs 33. The housing part 20 of the camera sub-assembly 10 is inserted into the retainer ring 31.

[0065] Additionally, as shown in Fig. 20B an additional insertion force 19 is applied so that housing part 20 of the camera sub-assembly 10. The insertion force 19 is necessary that the housing part 20 of the camera sub-assembly 10 gets over the initial interference with retainer ring 31. The insertion force 19 is parallel to the optical axis 11. After the retainer ring 31 has reached the final position the angular adjustment can be carried out. The gripping tool 26 is in contact with the gripping base 22 and applies the required adjustment torques to change the orientation of the optical axis 11. The gripping tool 26 is in contact with the gripping base 22 of the housing part 20 of the camera sub-assembly 10 until the glue (not shown here) is cured.

[0066] Fig. 21 is an enlarged sectional view of the camera sub-assembly 10 in the nominal position 23, wherein the camera sub-assembly 10 is held by the retainer ring 31. The retainer ring 31 mounted according to the steps shown in Figure 20A to 20B. The spherical outer topology 21 of the housing part 20 of the camera sub-assembly is in contact with the spheroidal inner topology 32 of the retainer ring 31. The retainer ring 31 matches the spherical outer contour 21 of the housing part 20 of the camera sub-assembly 10 at a position 23 of a maximal diameter of the housing part 20 of the camera sub-assembly 10. The diameter is perpendicular to the optical axis 11.

[0067] Fig. 22 is a side view of the camera sub-assembly 10, showing the possible orientations. The retai-

ner ring 31, as positioned in the embodiment shown in Fig. 21, limits the variety of the angle α around the nominal position of 15° . The marking 27 in Fig. 22 shows the limitation of the rotational movement of the housing part 20 of the camera sub-assembly 10 in the retainer ring 31. The rotational movement is limited by the gripping base 22 of the housing part 20.

[0068] Fig. 23A and 23B show a further unclaimed embodiment of the camera sub-assembly 10. The housing part 20 of the camera sub-assembly 10 has a spherical outer topology 21. The housing part 20 with the spherical outer topology 21 hosts a pattern of indexing holes 40 (recesses), which are arranged along one generatrix 41. The number of indexing holes 40 shall be chosen according to the desired increment of the adjustment angle.

[0069] Fig. 24 is a schematic view of an unclaimed embodiment of a mounting structure 30 for a camera sub-assembly 10 in an outer housing 7 of the system 1. The mounting structure 30 according to the embodiment shown here is defined by a spherical topology 8S of the housing cover 8 and an indexing pivot 50 sitting in the receptacle 16 of the housing base 9 of the outer housing 7. The housing cover 8 and the housing base 9 are made of aluminium. The spherical topology 8S of the housing cover 8 is in form fitting contact with the spherical outer topology 21 of the housing part 20 of the camera sub-assembly 10. The generatrix 41 of the housing part 20 with the indexing holes 40 is in contact with indexing teeth 52 of the indexing pivot 50. The indexing teeth 52 are arranged on a spherical sitting area 51. A bottom side 53 of the indexing pivot 50 has indexing fins 54. The indexing pivot 50 is fit to be manufactured out of a thermoplastic polymer (for example Polybutylenterephthalat (PBT), Acrylonitrile butadiene styrene (ABS), Polycarbonate (PC) etc.).

[0070] Fig. 25 is an enlarged view of the area marked with A in Fig. 24. The indexing pivot 50 has the spherical sitting area 51 with a groove 55 inside it. The groove 55 is as deep as needed in order to allow flexibility to indexing teeth 52. According to the embodiment as shown in Fig. 24 three indexing teeth 52 are located inside the groove 55 and are slightly projected outside. The indexing pivot 50 has a pivot shaft 58 which is sitting in the housing base 9. An air gap 59 is between the bottom side 53 and the housing base 9. Spring leaves 56 and stopper 57 are in the air gap 59 and ensure the stable positioning and movement of the indexing pivot 50.

[0071] Fig. 26 is a schematic top view of the indexing pivot 50 of the mounting structure as shown in Fig. 24. The indexing fins 54 (indicated with dashed lines), on the bottom side 53 (see Figs. 24 or 25) of the indexing pivot. In the embodiment shown here four indexing fins 54 are provided. The groove 55 of the spherical sitting area 51 has formed the indexing teeth 52. In the embodiment shown here three indexing teeth 52 are provided. The pivot shaft 58 of the indexing pivot 50 is arranged below the central indexing teeth 52.

[0072] Fig. 27 is a schematic top view of a rotational area of the mounting structure of Fig. 24. The housing base 9 has a special formed receptacle 16. Additionally, the receptacle 16 holds an indexing and sitting recess 60. As needed by application, the indexing and sitting recess 60 is positioned on the receptacle 16 of the housing base 9. The indexing and sitting recess 60 features a rotational area 62. The rotational area 62 has formed a rotational pattern of grooves 64. A central flat area 66 of the sitting recess 60 is used as a counter topology of for the indexing pivot 50 (see Fig. 25). The central flat area 66 has formed a hole 68 for fixation of the pivot shaft 58. The number of grooves 68 shall be chosen in accordance to the desired increment of adjustment angle. The sitting recess 60 is fit for manufacturing out of aluminium. It is obvious for any person skilled in the art that other material, like other metals or plastic materials, can be used instead of aluminium.

[0073] Fig. 28 is a schematic representation of the angular adjustment of the camera sub-assembly 10 with the mounting structure 30 as shown in Fig. 24. A preferred, cost effective solution, is to clamp the housing part 20 of the camera sub-assembly 10 with its spherical outer topology 21 in cooperation with the spherical topology 8S of the housing cover 8. Existing screws (not shown) can be used secure the housing cover 8 to the housing base 9. The indexing pivot 50 and the camera sub-assembly 10 are sandwiched between the housing cover 8 to the housing base 9. For tolerance compensation on assembly direction the spring leaves 56 are provided in the air gap 59 (see Fig. 25). The tolerance to be compensated is estimated to be less than 1 mm. The spring leaves 56 will be stiff enough so that the camera sub-assembly 10 will not rattle.

[0074] The assembly of the camera sub-assembly 10 to the outer housing 7 (housing cover 8 and housing base 9) comprises several steps. First, the camera sub-assembly 10 is gripped by the assembly jig 25. Next, the indexing pivot 50 is lowered toward the housing base 9 and the pivot shaft 58 being pushed through the hole 68 of the central flat area 66 (see Fig. 27). Thereby the pivot shaft 58 is fixed the housing base 9. As pivot shaft 58 shaft is pushed in, the pivot shaft 58 becomes captive while the spring leaves 56 become tense (see Fig. 25). Then the camera sub-assembly 10 is lowered onto the indexing pivot 50, in a way so that the indexing teeth 52 of the indexing pivot 50 reach the respective indexing holes 40 inside the housing part 20 of the camera sub-assembly 10. As this is accomplished, the spherical sitting area 51 of indexing pivot 50 gets in contact with the spherical outer topology 21 housing part 20 of the camera sub-assembly 10 camera (except for the groove 55). Next the housing cover 8 is lowered onto the housing base 9 and becomes fully in contact with the housing base 9. The spring leaves 58 of the indexing pivot 50 accommodate the overlap and the spherical topology 8S of the housing cover 8 gets into contact with the spherical outer topology 21 of the housing part 20 of the camera sub-assembly 10.

The two adjustment angles are adjusted to the functional position of the assembly, as required by the parameters of the vehicle 2. The adjustment is carried out with the help of the gripping tool 26. The solutions for gripping may vary and the solution shown in Fig. 28 should not be regarded as a limitation of the invention.

[0075] When the housing part 20 of the camera sub-assembly 10 is rotated in a first direction 70, the indexing teeth 52 on the indexing pivot 50 will get into contact with another set of indexing holes 40 in the spherical outer topology 21 of the housing part 20 of the camera sub-assembly 10. Due to the indexing, the angular adjustment shall be done in steps equal to the angular ratio of hole pattern. Only the housing part 20 of the camera sub-assembly 10 is rotated.

[0076] When the housing part 20 of the camera sub-assembly 10 is in a second direction 80, the indexing fins 54 on the indexing pivot 50 will get into contact with the set of indexing grooves 64 of the indexing and sitting recess 60 (see Fig. 27). The housing part 20 of the camera sub-assembly 10 and the indexing pivot 50 rotate together. Due to the indexing, the angular adjustment shall be done in steps equal to the angular ratio of groove pattern of the indexing and sitting recess 60. The rotation moment is transferred from the gripping tool 26 to the housing part 20 of the camera sub-assembly 10 to the indexing teeth 52 of the indexing pivot 50 and to the indexing fins 54 of the indexing pivot 50.

[0077] The set of the angular adjustment of the housing part 20 of the camera sub-assembly 10 can be carried out optionally in the manufacturer's plant. The elasticity of the indexing teeth 52 and the indexing fins 54 ensure an easy position change.

[0078] It is believed that the present disclosure and many of its attendant advantages will be understood by the foregoing description, and it will be apparent that various changes may be made in the form, construction and arrangement of the components without departing from the disclosed subject matter or without sacrificing all of its material advantages. The form described is merely explanatory, and it is the intention of the following claims to encompass and include such changes. Accordingly, the scope of the invention should be limited only by the claims appended hereto.

LIST OF REFERENCE NUMERALS

[0079]

1 System
2 Vehicle
3 Windshield
4 Lens
5 Driver
6 Mounting ear
7 Outer housing
8 Housing cover
8S Spherical topology

9 Housing base
9I Inner portion
9W Wall
10 Camera sub-assembly
5 11 Optical axis
12 Infrared module
13 Aperture opening
14 Cooling dome
15 Nominal position
10 16 Receptacle
17 Infrared diode
18 Guiding pin
19 Force
20 Housing part of the camera sub-assembly
15 21 Spherical outer topology
22 Gripping base
23 Position
25 Jig
26 Gripping tool
20 27 Marking
29 Rotation
30 Mounting structure
31 Retainer ring
32 Spheroidal inner topology
25 33 Lug
34 Window
35 Centring holes
36 Middle plane
38 Seam
30 39 Glue
40 Indexing hole
41 Generatrix
50 Indexing pivot
51 Spherical sitting area
35 52 Indexing tooth
53 Bottom side
54 Indexing fin
55 Groove
56 Spring leave
40 57 Stopper
58 Pivot shaft
59 Air gap
60 Indexing and sitting recess
62 Rotational area
45 64 Groove
66 Central flat area
68 Hole
70 First direction
80 Second direction
50 100 Vision camera
101 Camera housing
102 Imager sensor
103 Printed circuit board
105 Fixing glue
55 106 Lens barrel
107 Electronic device
110 Housing part

Claims

1. A system (1) mounted at or close to a windshield (3) of a motor vehicle (2), looking at a driver (5) of the motor vehicle (2), comprising:

at least a camera sub-assembly (10) positioned in an outer housing (7) so that its optical axis (11) is pointing to an outside of the outer housing (7), wherein the outer housing (7) is defined by a housing cover (8) and a housing base (9), a housing part (20) for the camera sub-assembly (10), wherein the housing part has a spherical outer topology (21),

a mounting structure (30), wherein the mounting structure (30) is a retainer ring (31), which is positioned in a receptacle (16) of the housing base (9);

wherein the camera sub-assembly (10) is surrounded by the retainer ring, wherein a spheroidal inner topology (32) of the retainer ring (31) matches the spherical outer contour (21) of the housing part (20) of the camera sub-assembly (10), which allows an angular adjustment of the optical axis (11) of the camera sub-assembly (10); and

characterized in that the retainer ring (31) comprises at least one window (34), wherein a glue (39) is received in the at least one window (34) to fix the angular adjusted optical axis (11) of the camera sub-assembly (10) .

2. The system (1) as claimed in claim 1, wherein the spherical inner topology (32) of the retainer ring (31) is centred in a middle plane (36) of the retainer ring (31) and the spherical inner topology (32) of the retainer ring (31) matches the spherical outer contour (21) of the housing part (20) of the camera sub-assembly (10) at a position (23) of a maximal diameter of the housing part (20) of the camera sub-assembly (10) which is perpendicular to the optical axis (11).

3. The system (1) as claimed in claim 1, wherein the cured glue (39) blocks a relative movement of the retainer ring (31) and the spherical outer contour (21) of the housing part (20) of the camera sub-assembly (10).

4. The system (1) as claimed in claim 1, wherein the housing part (20) of the camera sub-assembly (10) and the retainer ring (31) are manufactured from the same material.

5. The system as claimed in any of the preceding claims, wherein the receptacle (16) of the housing base (9) has two guiding pins (18) which reach into respective centring holes (35) of the retainer ring (31)

formed in lugs (33) of the retainer ring (31).

6. A method for manufacturing a system (1) to be mounted at or close to a windshield (3) of a motor vehicle (2), looking at a driver (5) of the motor vehicle (2), wherein the system (1) comprises at least a camera sub-assembly (10) positioned in an outer housing (7) so that its optical axis (11) is pointing to an outside of the outer housing (7), and the outer housing (7) is defined by a housing cover (8) and a housing base (9),

comprising the steps of:

- fixing a retainer ring (31) inside a jig (25);
- positioning a housing part (20) of the camera sub-assembly (10) to be surrounded by the retainer ring (31) and so that the

optical axis (11) is perpendicular to the retainer ring (31), wherein the retainer ring (31) is a mounting structure (30);

- adjusting an angular orientation of the optical axis (11) of the camera sub-assembly (10) in that a spheroidal inner topology (32) of the retainer ring (31) matches a spherical outer contour (21) of the housing part (20) of the camera sub-assembly (10);
- applying a glue (39) in at least one window (34) of the retainer ring (31) after the angular orientation of the optical axis (11) of the camera sub-assembly (10);
- curing the glue (39);
- positioning the retainer ring (31) with a fixed spatial orientation of the optical axis (11) of the camera sub-assembly (10) in a receptacle (16) of the housing base (9); and
- mounting the housing cover (8) to the housing base (9) so that the housing part (20) of the camera sub-assembly (10) is held by the outer housing cover (7).

7. The method as claimed in claim 6, wherein an orientation of the optical axis (11) of the camera sub-assembly (10) is adjusted by a gripping tool (26) prior to positioning the retainer ring (31) on the receptacle (16) of the housing base (9).

8. The method as claimed in claim 6, wherein the glue (39) is further applied as a seam (38) between the retainer ring (31) and the spherical outer topology (21) of the housing part (20) .

9. The method as claimed in any of the preceding claims 6 to 8, wherein the positioning of the retainer ring (31) in the receptacle (16) of the housing base (9) is achieved by guiding pins (18) of the receptacle

(16) which reach into centring holes (35) of lugs (33) of the retainer ring (31).

(20) der Kameraunterbaugruppe (10) und der Haltering (31) aus demselben Material gefertigt sind.

Patentansprüche

1. Ein System (1), das an oder in der Nähe einer Windschutzscheibe (3) eines Kraftfahrzeugs (2) angebracht ist, das auf einen Fahrer (5) des Kraftfahrzeugs (2) blickt, umfassend:

mindestens eine Kameraunterbaugruppe (10), die in einem Außengehäuse (7) so positioniert ist, dass ihre optische Achse (11) zu einer Außenseite des Außengehäuses (7) zeigt, wobei das Außengehäuse (7) durch eine Gehäuseabdeckung (8) und einen Gehäuseboden (9) definiert ist,

ein Gehäuseteil (20) für die Kameraunterbaugruppe (10), wobei das Gehäuseteil (20) eine kugelförmige Außentopologie (21) aufweist, eine Montagestruktur (30), wobei die Montagestruktur (30) ein Haltering (31) ist, der in einer Aufnahme (16) des Gehäusebodens (9) positioniert ist; und

wobei die Kameraunterbaugruppe (10) von dem Haltering (31) umgeben ist, wobei eine ellipsenförmige Innentopologie (32) des Halterings (31) mit der kugelförmigen Außenkontur (21) des Gehäuseteils (20) der Kameraunterbaugruppe (10) übereinstimmt, was eine Winkelverstellung der optischen Achse (11) der Kameraunterbaugruppe (10) ermöglicht;

dadurch gekennzeichnet, dass der Haltering (31) mindestens ein Fenster (34) aufweist, wobei in dem mindestens einen Fenster (34) ein Klebstoff (39) aufgenommen ist, um die winkelverstellte optische Achse (11) der Kameraunterbaugruppe (10) zu fixieren.

2. Das System (1) nach Anspruch 1, wobei die kugelförmige Innentopologie (32) des Halterings (31) in einer Mittelebene (36) des Halterings (31) zentriert ist und die kugelförmige Innentopologie (32) des Halterings (31) mit der kugelförmigen Außenkontur (21) des Gehäuseteils (20) der Kameraunterbaugruppe (10) an einer Position (23) eines maximalen Durchmessers des Gehäuseteils (20) der Kameraunterbaugruppe (10) übereinstimmt, die senkrecht zur optischen Achse (11) ist.

3. Das System (1) nach Anspruch 1, wobei der ausgehärtete Klebstoff (39) eine Relativbewegung zwischen dem Haltering (31) und der kugelförmigen Außenkontur (21) des Gehäuseteils (20) der Kameraunterbaugruppe (10) blockiert.

4. System (1) nach Anspruch 1, wobei das Gehäuseteil

5. Das System (1) nach einem der vorhergehenden Ansprüche, wobei die Aufnahme (16) des Gehäusebodens (9) zwei Führungsstifte (18) aufweist, die jeweils in entsprechende Zentrierlöcher (35) des Halterings (31) eingreifen, die in Nasen (33) des Halterings (31) ausgebildet sind.

6. Ein Verfahren zur Herstellung eines Systems (1), das an oder in der Nähe einer Windschutzscheibe (3) eines Kraftfahrzeugs (2) zu montieren ist und auf einen Fahrer (5) des Kraftfahrzeugs (2) blickt, wobei das System (1) mindestens eine Kameraunterbaugruppe (10) umfasst, die in einem Außengehäuse (7) so positioniert ist, dass ihre optische Achse (11) zu einer Außenseite des Außengehäuses (7) zeigt, und das Außengehäuse (7) durch eine Gehäuseabdeckung (8) und einen Gehäuseboden (9) definiert ist, mit den folgenden Schritten:

- Befestigen eines Halterings (31) im Inneren einer Einsetzvorrichtung (25);

- Positionieren eines Gehäuseteils (20) der Kameraunterbaugruppe (10), um von dem Haltering (31) umgeben zu sein, und so, dass die optische Achse (11) senkrecht zu dem Haltering (31) ist, wobei der Haltering (31) eine Montagestruktur (30) ist;

- Einstellen einer Winkelausrichtung der optischen Achse (11) der Kameraunterbaugruppe (10), so dass eine ellipsenförmige Innentopologie (32) des Halterings (31) mit einer kugelförmigen Außenkontur (21) des Gehäuseteils (20) der Kameraunterbaugruppe (10) übereinstimmt;

- Aufbringen eines Klebstoffs (39) in mindestens einem Fenster (34) des Halterings (31) nach der Winkelausrichtung der optischen Achse (11) der Kameraunterbaugruppe (10);

- Aushärten des Klebstoffs (39);

- Positionieren des Halterings (31) mit einer festen räumlichen Ausrichtung der optischen Achse (11) der Kameraunterbaugruppe (10) in einer Aufnahme (16) des Gehäusebodens (9); und

- Anbringen der Gehäuseabdeckung (8) am Gehäuseboden (9), so dass das Gehäuseteil (20) der Kameraunterbaugruppe (10) von der Außengehäuseabdeckung (7) gehalten wird.

7. Das Verfahren nach Anspruch 6, wobei eine Ausrichtung der optischen Achse (11) der Kameraunterbaugruppe (10) durch ein Greifwerkzeug (26) eingestellt wird, bevor der Haltering (31) auf der Aufnahme (16) des Gehäusebodens (9) positioniert wird.

8. Das Verfahren nach Anspruch 6, wobei der Klebstoff (39) ferner als eine Naht (38) zwischen dem Haltering (31) und der kugelförmigen Außentopologie (21) des Gehäuseteils (20) aufgebracht wird.
9. Das Verfahren nach einem der Ansprüche 6 bis 8, wobei die Positionierung des Halterings (31) in der Aufnahme (16) des Gehäusebodens (9) durch Führungsstifte (18) der Aufnahme (16) erreicht wird, die in Zentrierlöcher (35) von Nasen (33) des Halterings (31) greifen.

Revendications

1. Un système (1) monté sur ou à proximité d'un pare-brise (3) d'un véhicule automobile (2), orienté vers un conducteur (5) du véhicule automobile (2), comprenant :

au moins un sous-ensemble de caméra (10) positionné dans un boîtier extérieur (7) de telle sorte que son axe optique (11) soit dirigé vers l'extérieur du boîtier extérieur (7), le boîtier extérieur (7) étant défini par un couvercle de boîtier (8) et une base de boîtier (9),

une partie de boîtier (20) pour le sous-ensemble de caméra (10), dans lequel la partie de boîtier (20) présente une topologie extérieure sphérique (21) ,

une structure de montage (30), dans laquelle la structure de montage (30) est une bague de retenue (31), qui est positionnée dans un logement (16) de la base de boîtier (9) ; et

dans lequel le sous-ensemble de caméra (10) est entouré par la bague de retenue (31), dans lequel une topologie intérieure sphéroïdale (32) de la bague de retenue (31) correspond au contour extérieur sphérique (21) de la partie de boîtier (20) du sous-ensemble de caméra (10), ce qui permet un réglage angulaire de l'axe optique (11) du sous-ensemble de caméra (10) ; **caractérisé en ce que** la bague de retenue (31) comprend au moins une fenêtre (34), dans laquelle est logé un adhésif (39) afin de fixer l'axe optique (11) du sous-ensemble de caméra (10), dont l'orientation angulaire a été ajustée.

2. Le système (1) selon la revendication 1, dans lequel la topologie intérieure sphérique (32) de la bague de retenue (31) est centrée dans un plan médian (36) de la bague de retenue (31) et la topologie intérieure sphérique (32) de la bague de retenue (31) correspond au contour extérieur sphérique (21) de la partie de boîtier (20) du sous-ensemble de caméra (10) en une position (23) de diamètre maximal de la partie de boîtier (20) du sous-ensemble de caméra (10) qui est perpendiculaire à l'axe optique (11).

3. Le système (1) selon la revendication 1, dans lequel l'adhésif durci (39) empêche tout mouvement relatif entre la bague de retenue (31) et le contour extérieur sphérique (21) de la partie de boîtier (20) du sous-ensemble de caméra (10).

4. Le système (1) selon la revendication 1, dans lequel la partie de boîtier (20) du sous-ensemble de caméra (10) et la bague de retenue (31) sont fabriquées dans le même matériau.

5. Le système (1) selon l'une quelconque des revendications précédentes, dans lequel le logement (16) de la base de boîtier (9) comporte deux broches de guidage (18) qui s'engagent dans des trous de centrage (35) respectifs de la bague de retenue (31) formés dans des pattes (33) de la bague de retenue (31).

6. Un procédé de fabrication d'un système (1) destiné à être monté sur ou à proximité d'un pare-brise (3) d'un véhicule automobile (2), orienté vers un conducteur (5) du véhicule automobile (2), dans lequel le système (1) comprend au moins un sous-ensemble de caméra (10) positionné dans un boîtier extérieur (7) de telle sorte que son axe optique (11) soit dirigé vers l'extérieur du boîtier extérieur (7), et le boîtier extérieur (7) est défini par un couvercle de boîtier (8) et une base de boîtier (9),

comprenant les étapes suivantes :

- fixer une bague de retenue (31) à l'intérieur d'un gabarit (25) ;
- positionner une partie de boîtier (20) du sous-ensemble de caméra (10) de manière à ce qu'elle soit entourée par la bague de retenue (31) et que l'axe optique (11) soit perpendiculaire à la bague de retenue (31), la bague de retenue (31) étant une structure de montage (30) ;
- ajuster une orientation angulaire de l'axe optique (11) du sous-ensemble de caméra (10) de telle sorte qu'une topologie intérieure sphéroïdale (32) de la bague de retenue (31) s'adapte à un contour extérieur sphérique (21) de la partie de boîtier (20) du sous-ensemble de caméra (10) ;
- appliquer un adhésif (39) dans au moins une fenêtre (34) de la bague de retenue (31) après de l'orientation angulaire de l'axe optique (11) du sous-ensemble de caméra (10) ;
- durcir l'adhésif (39) ;
- positionner la bague de retenue (31) avec une orientation spatiale fixe de l'axe optique (11) du sous-ensemble de caméra (10) dans un logement (16) de la base du boîtier (9) ; et
- monter le couvercle de boîtier (8) sur la base de boîtier (9) de telle sorte que la partie de boîtier

(20) du sous-ensemble de caméra (10) soit maintenue par le couvercle de boîtier extérieur (7).

7. Le procédé selon la revendication 6, dans lequel l'orientation de l'axe optique (11) du sous-ensemble de caméra (10) est ajustée à l'aide d'un outil de préhension (26) avant le positionnement de la bague de retenue (31) sur le logement (16) de la base du boîtier (9). 5 10
8. Le procédé selon la revendication 6, dans lequel l'adhésif (39) est en outre appliqué sous forme d'une couture (38) entre la bague de retenue (31) et la topologie extérieure sphérique (21) de la partie de boîtier (20). 15
9. Le procédé selon l'une quelconque des revendications 6 à 8 précédentes, dans lequel le positionnement de la bague de retenue (31) dans le logement (16) de la base de boîtier (9) est réalisé par des broches de guidage (18) du logement (16) qui s'engagent dans des trous de centrage (35) de pattes (33) de la bague de retenue (31). 20 25

30

35

40

45

50

55

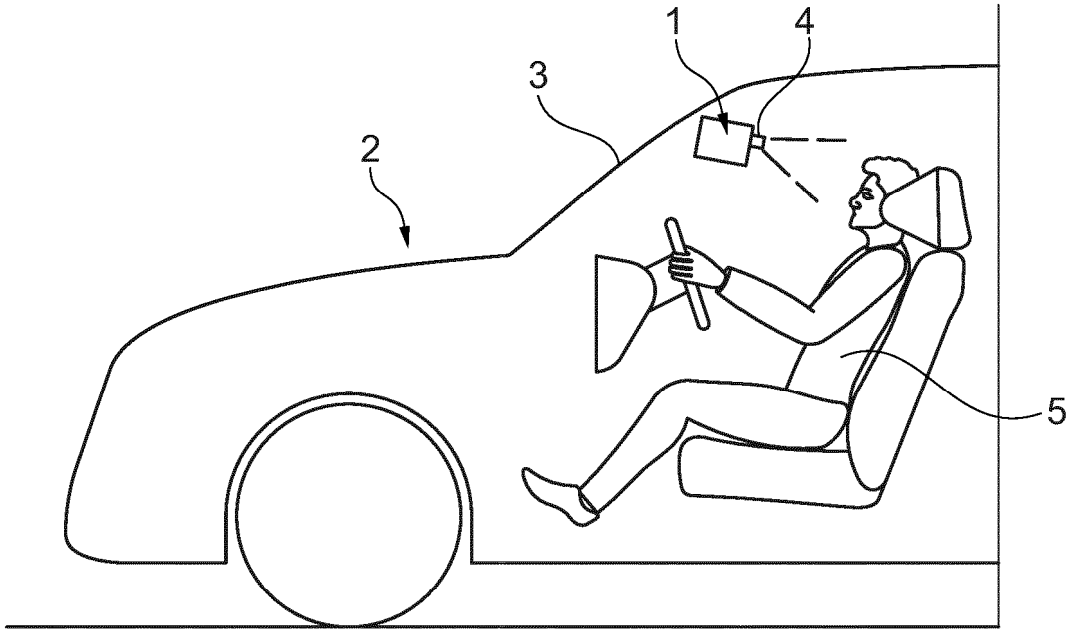

Prior art
Fig. 1

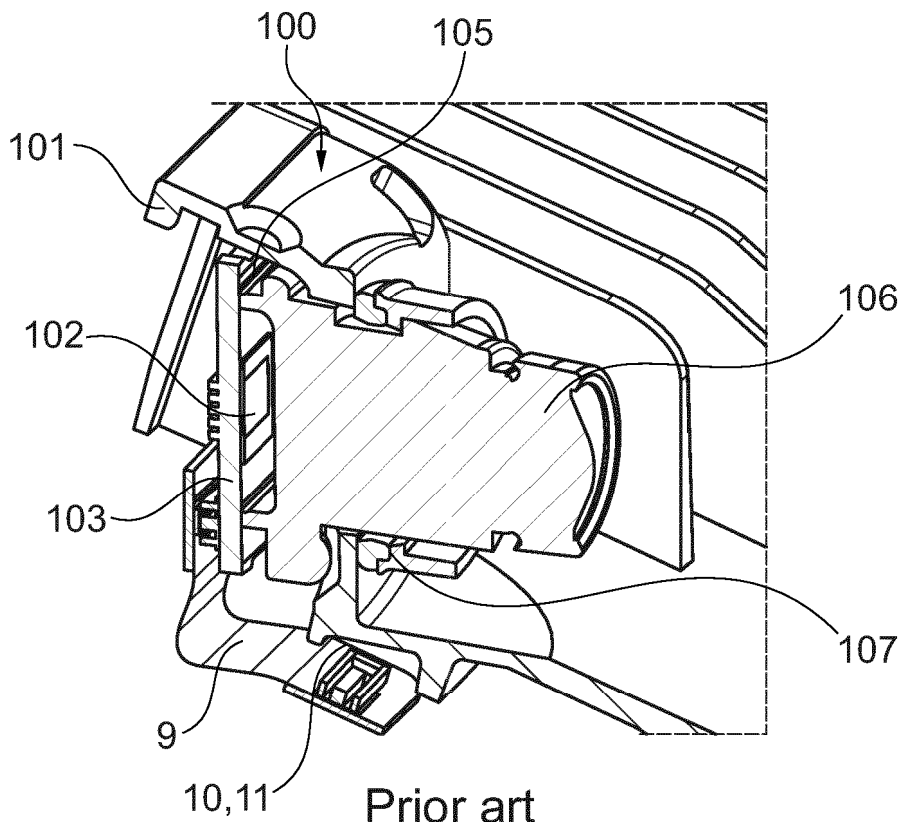

Prior art
Fig. 2

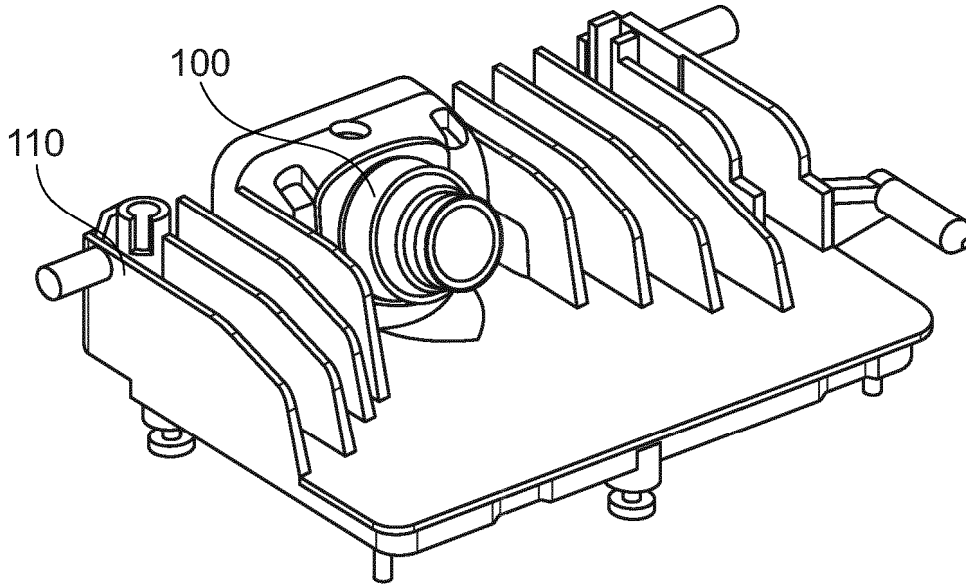

Prior art
Fig. 3

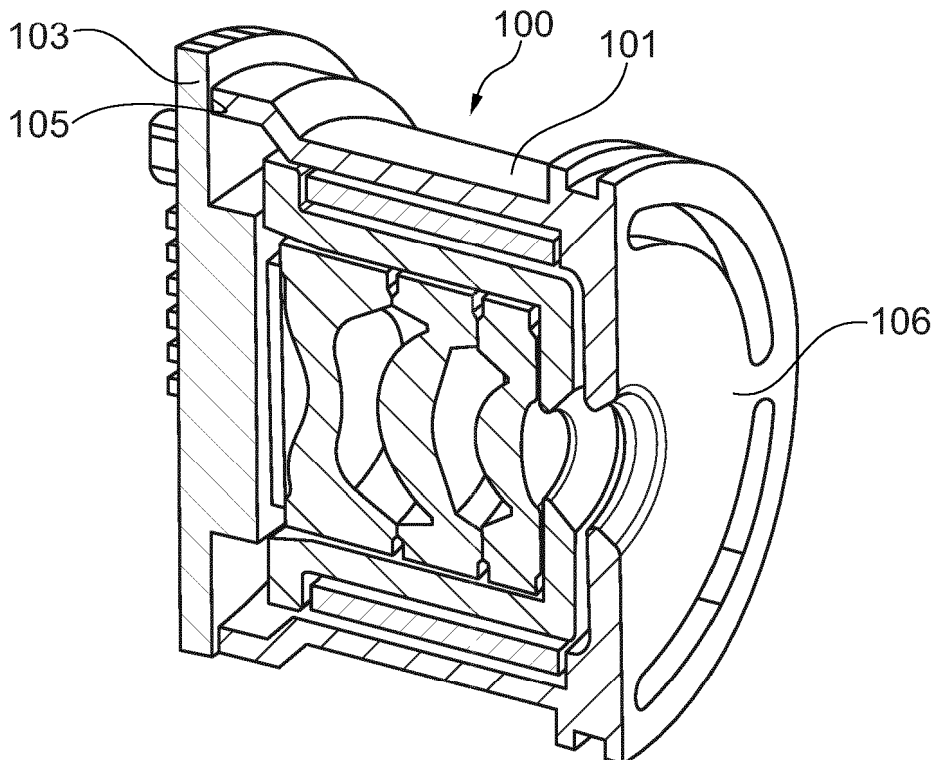

Prior art
Fig. 4

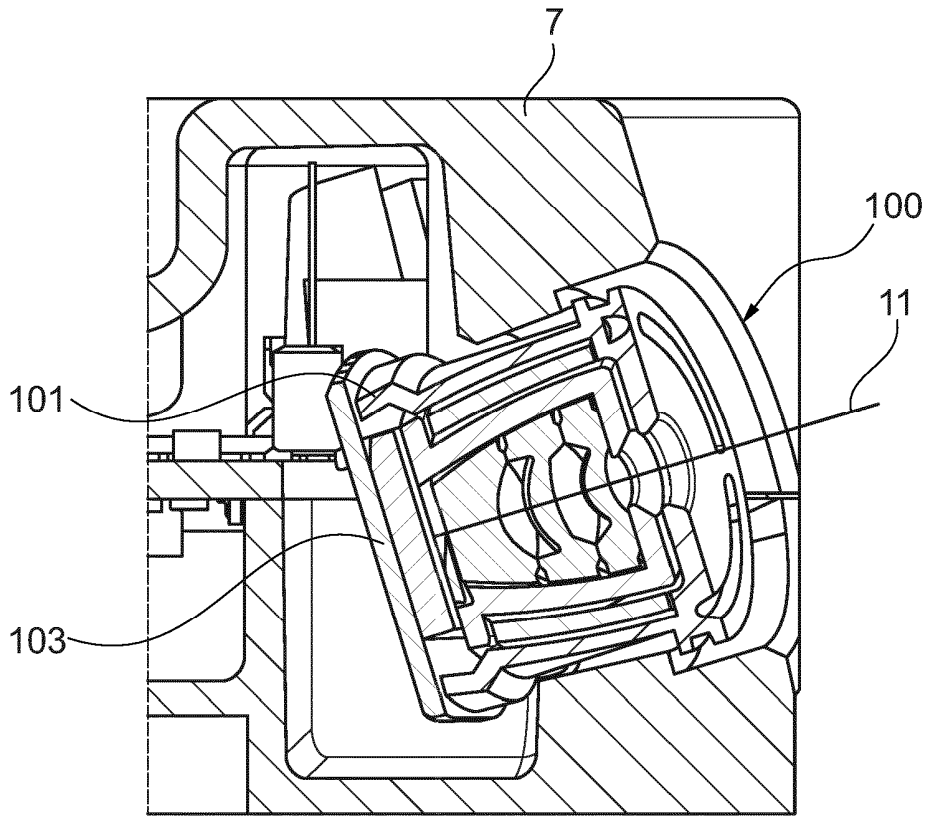

Fig. 5

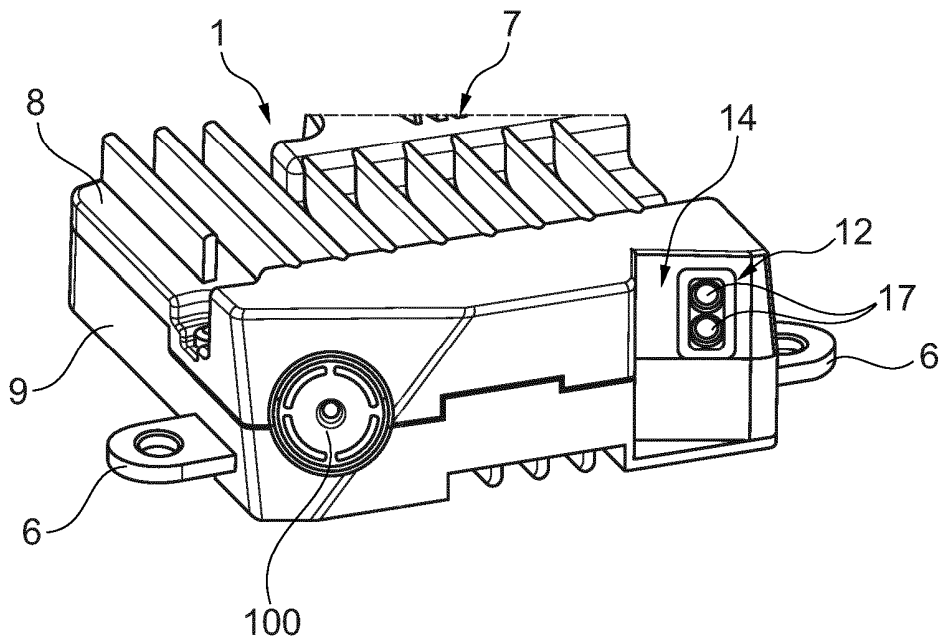

Fig. 6

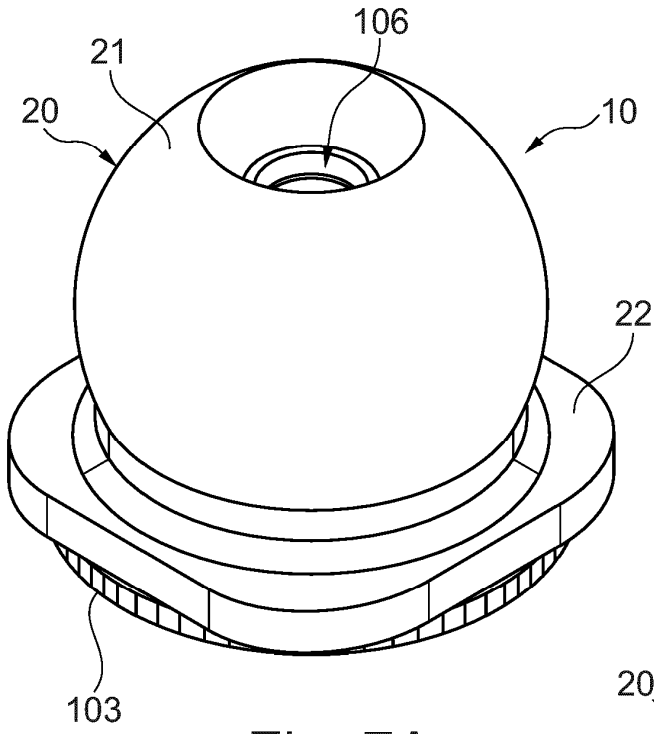

Fig. 7A

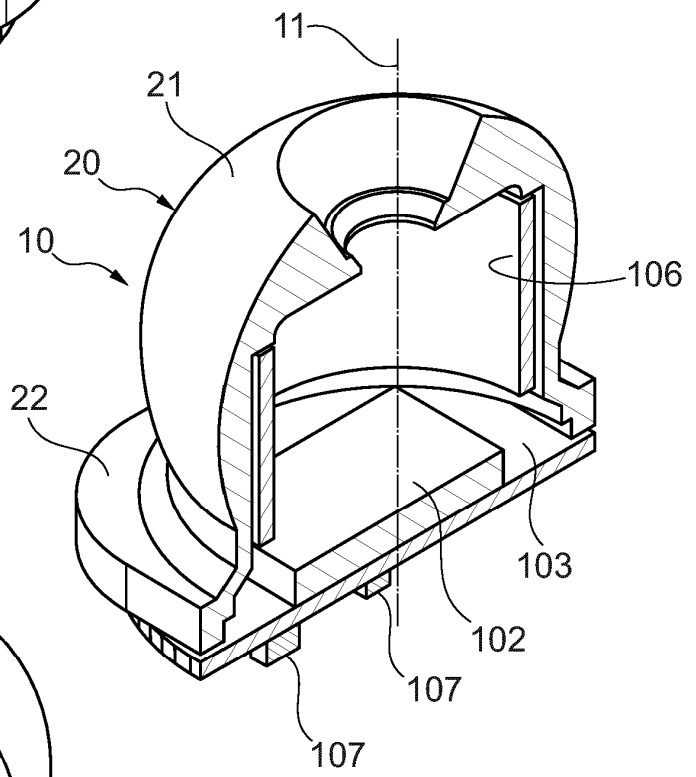

Fig. 7B

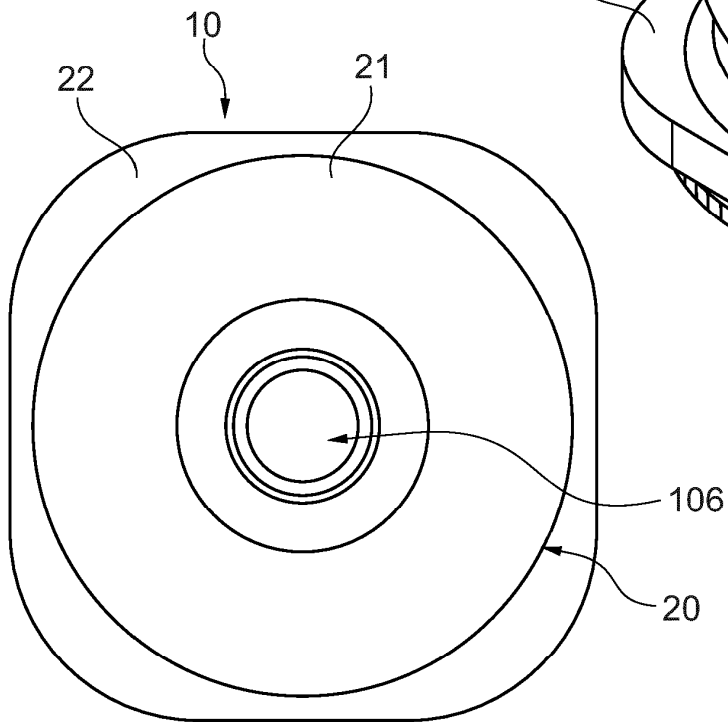

Fig. 7C

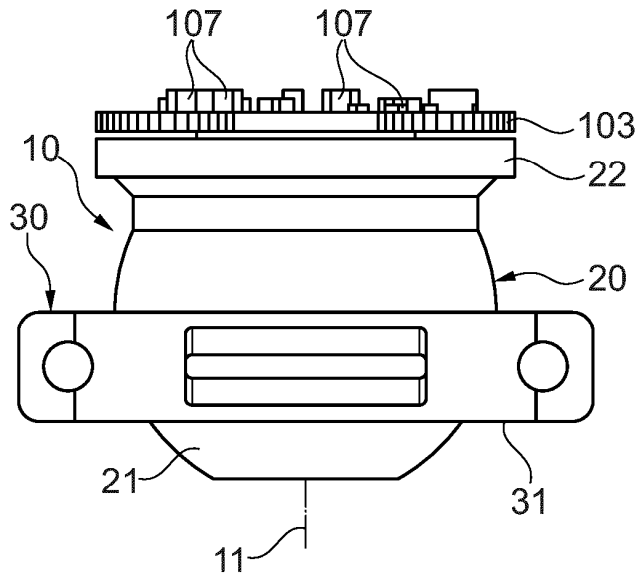

Fig. 8A

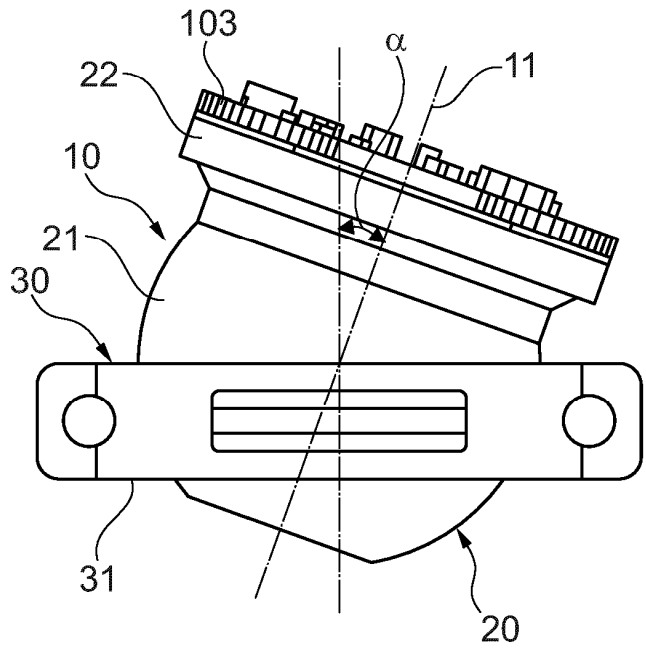

Fig. 8B

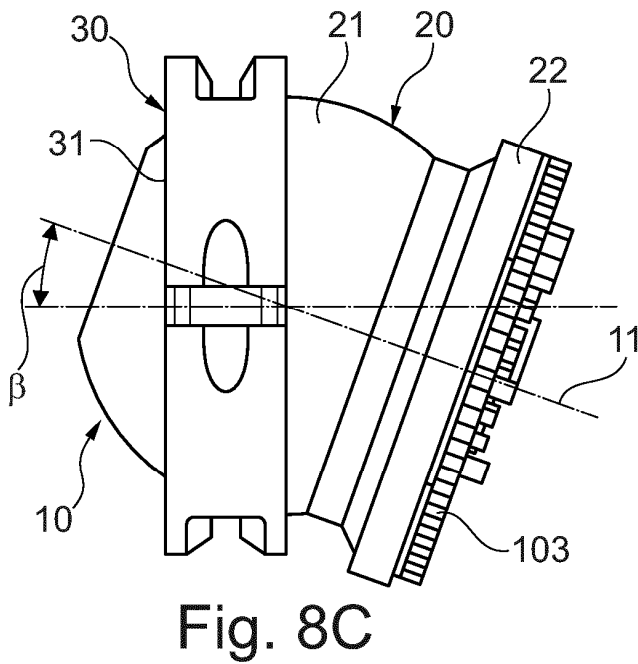

Fig. 8C

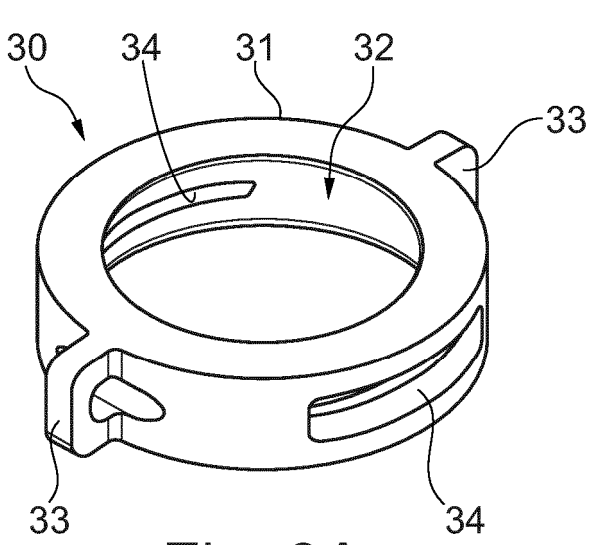

Fig. 9A

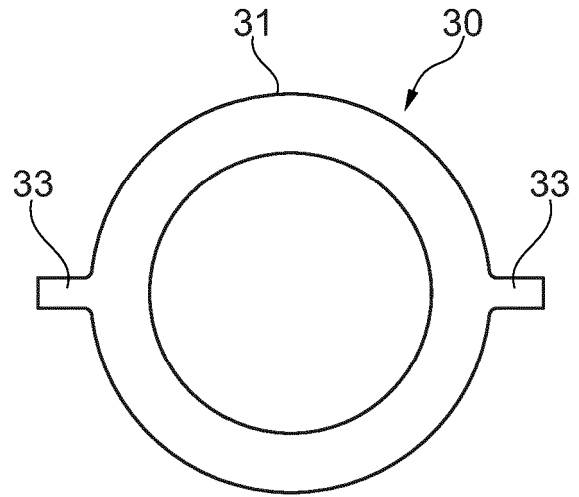

Fig. 9B

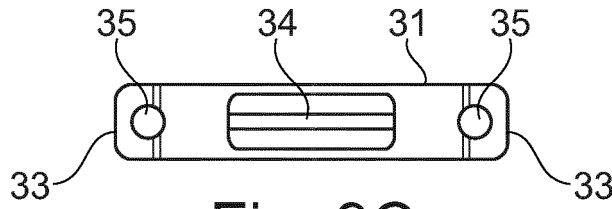

Fig. 9C

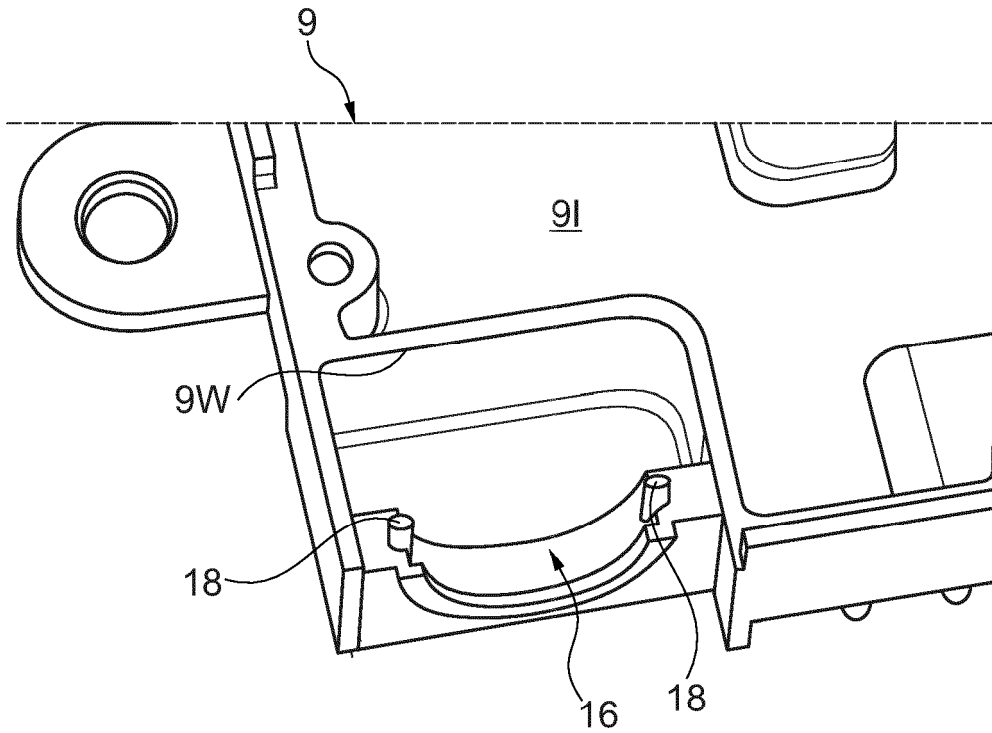
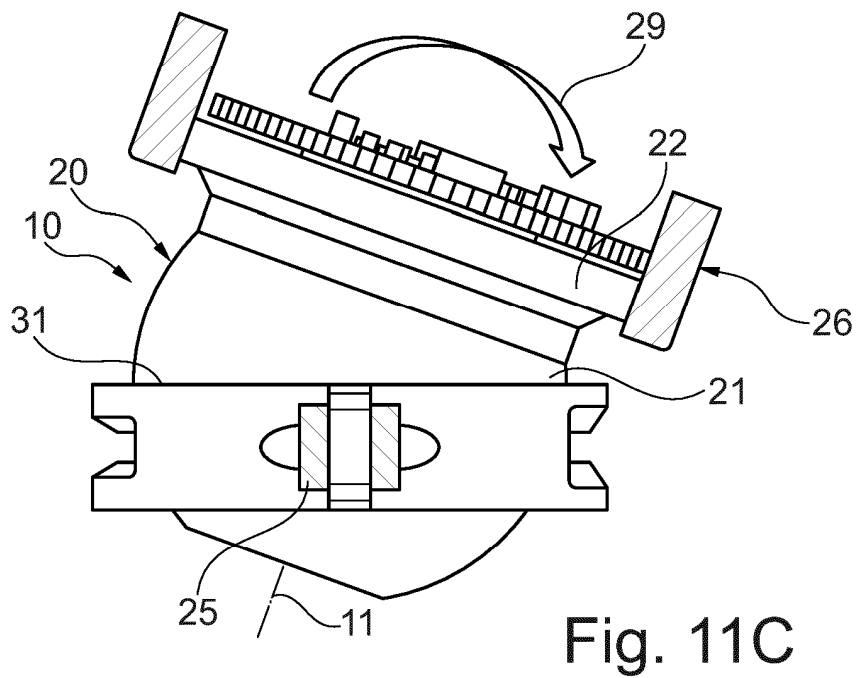
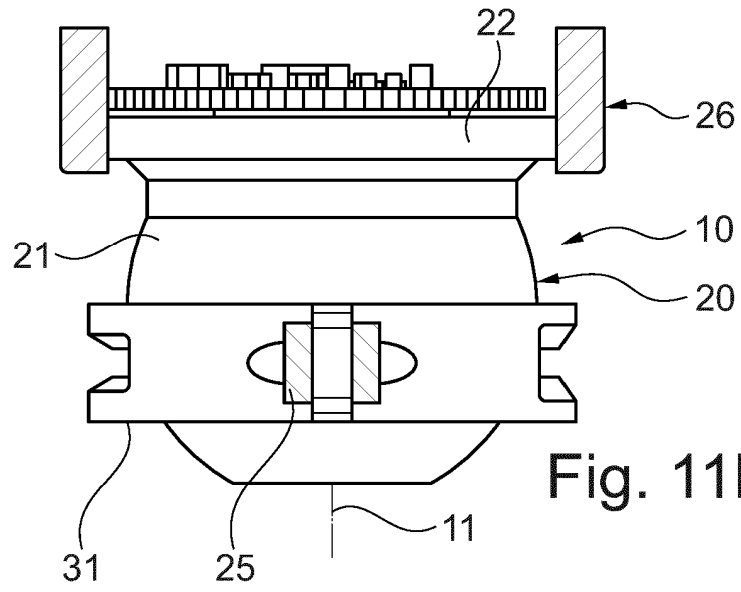
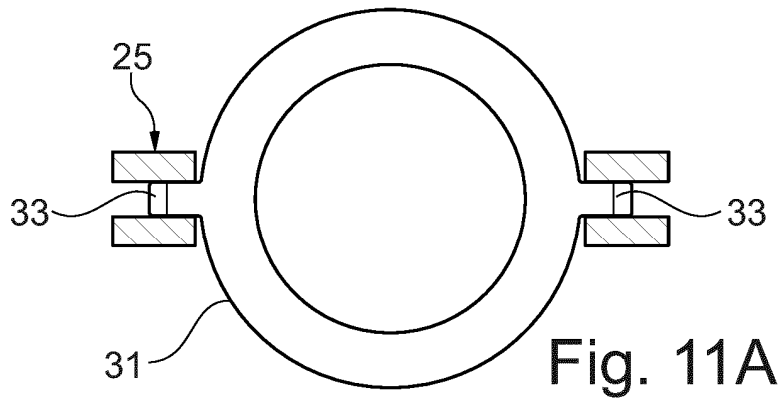

Fig. 10



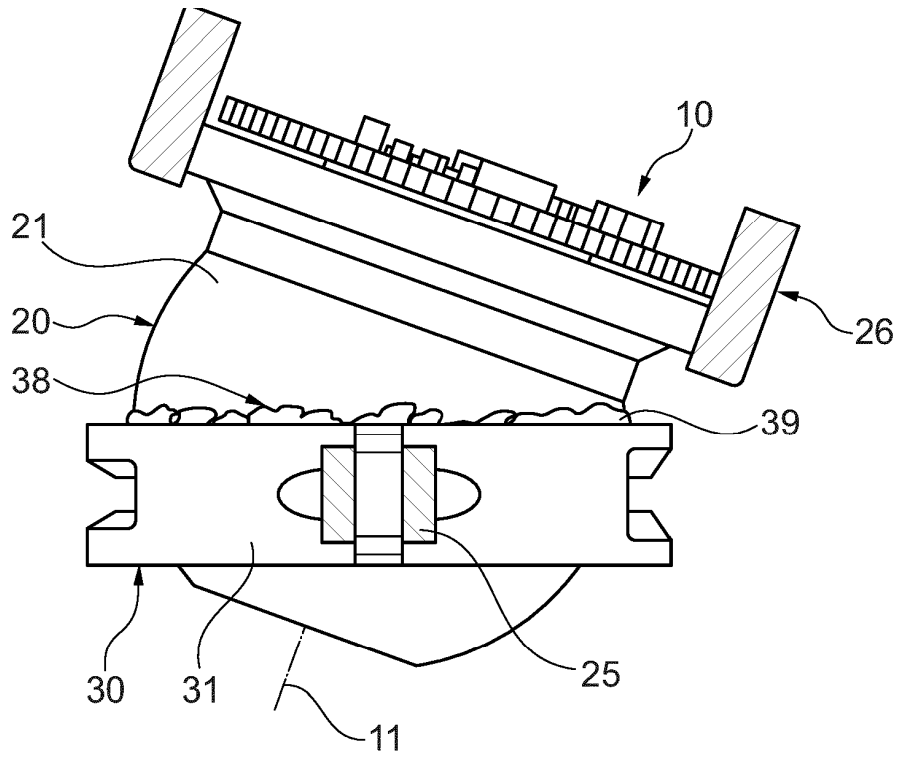

Fig. 11D

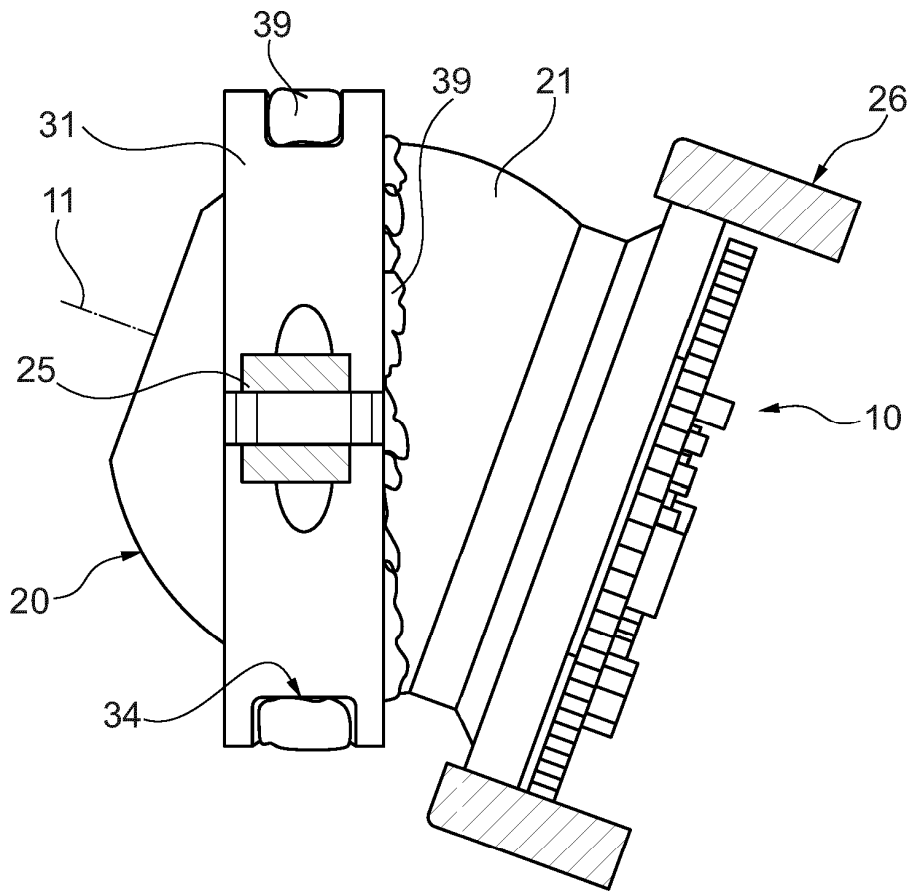

Fig. 11E

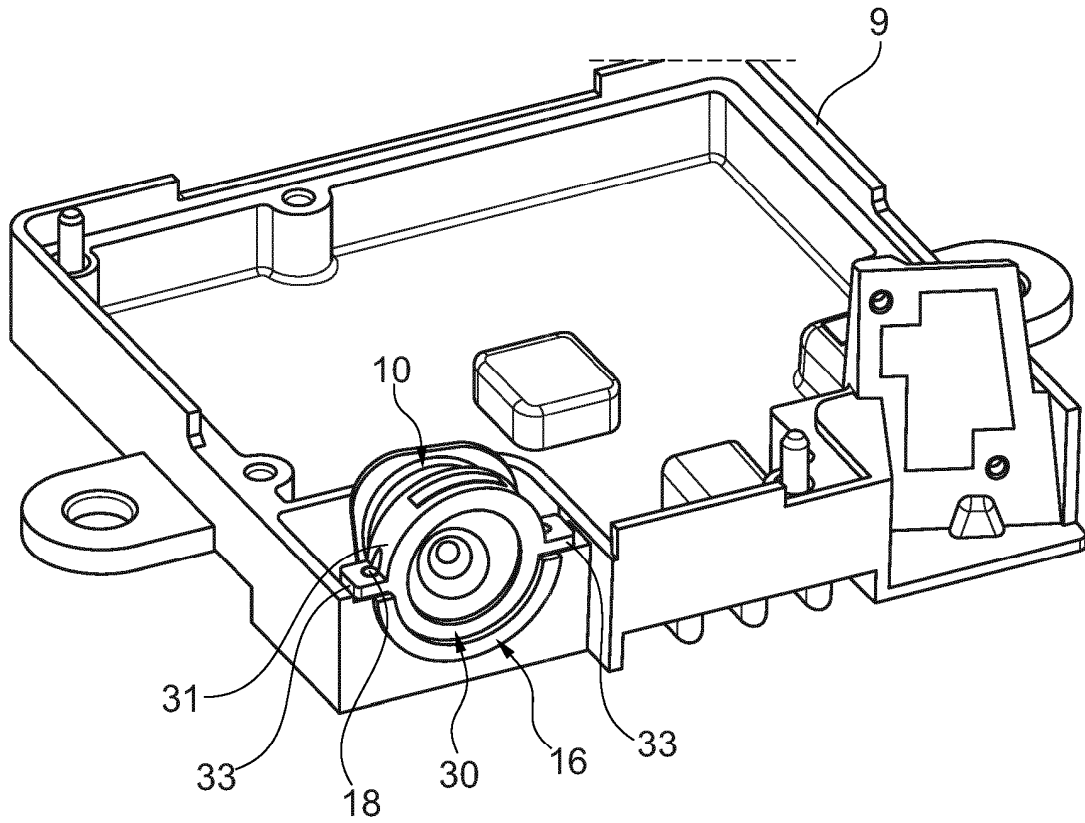

Fig. 12

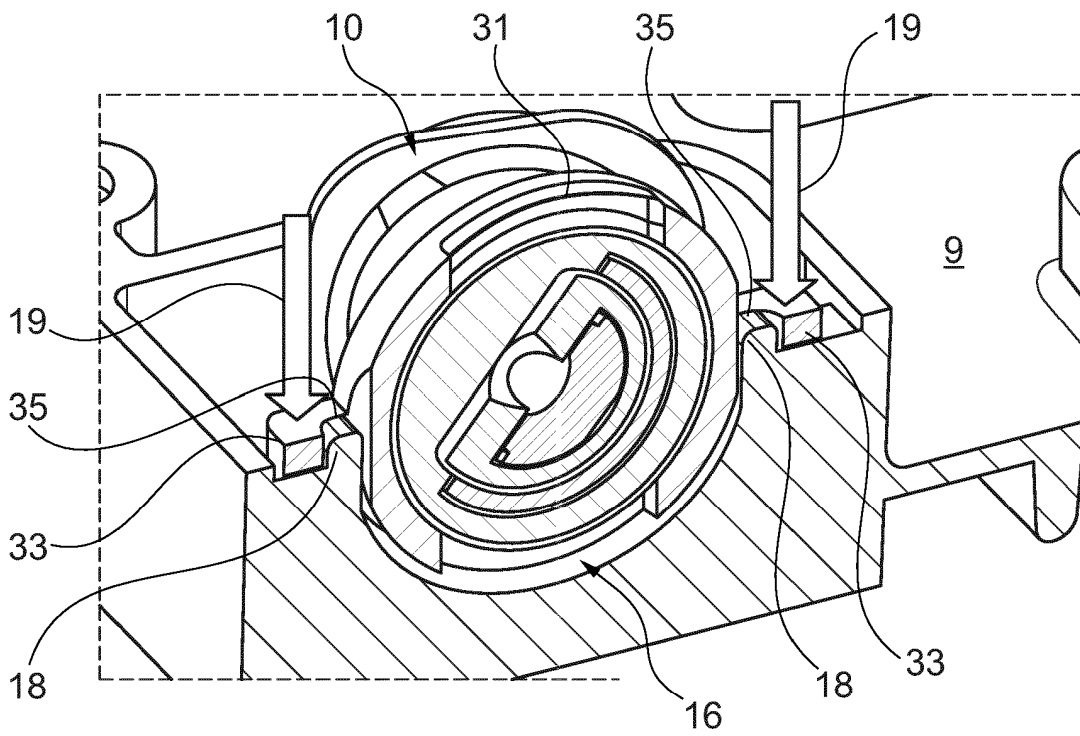

Fig. 13

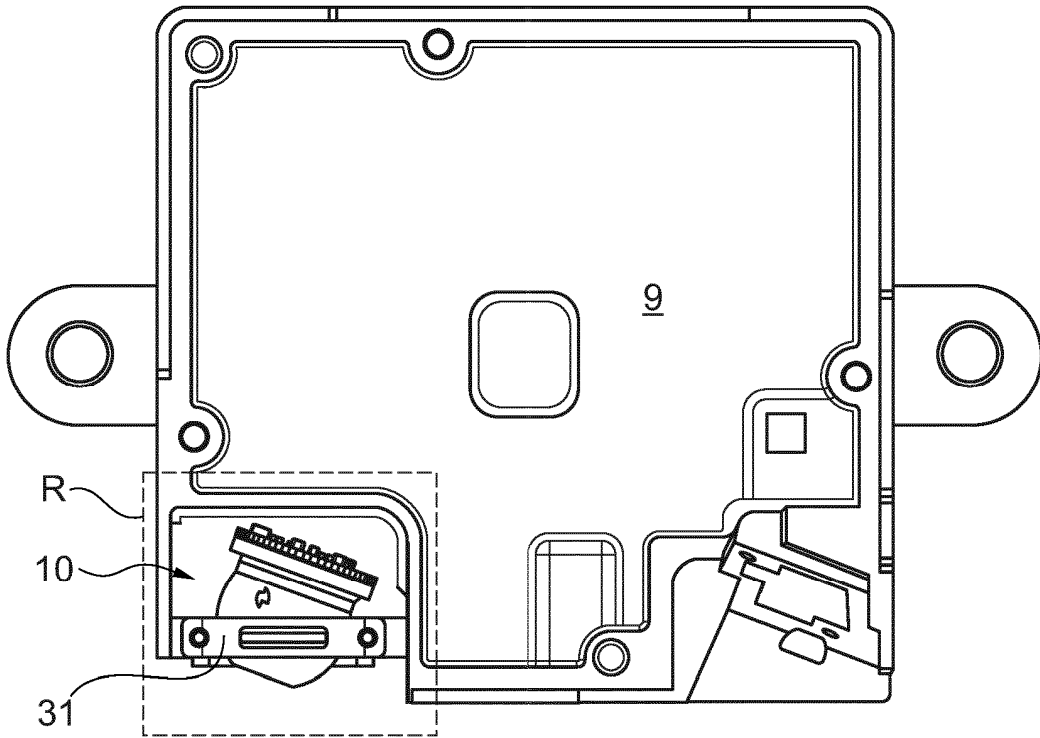

Fig. 14

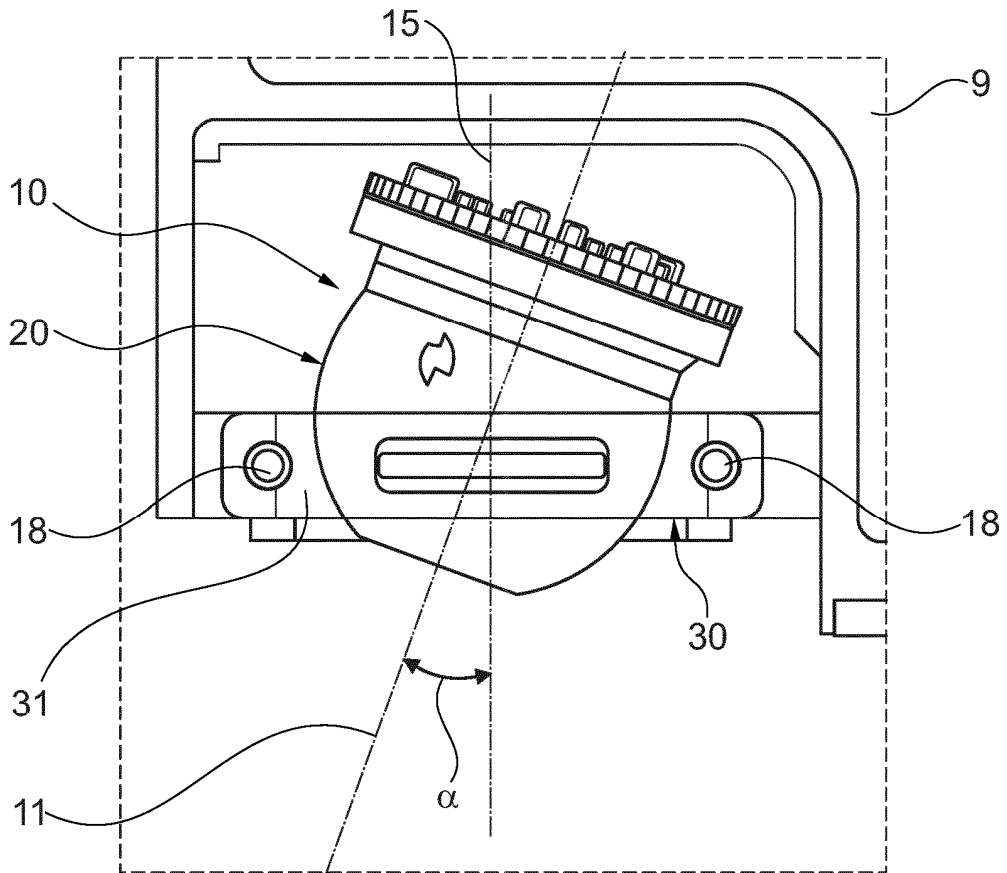

Fig. 15

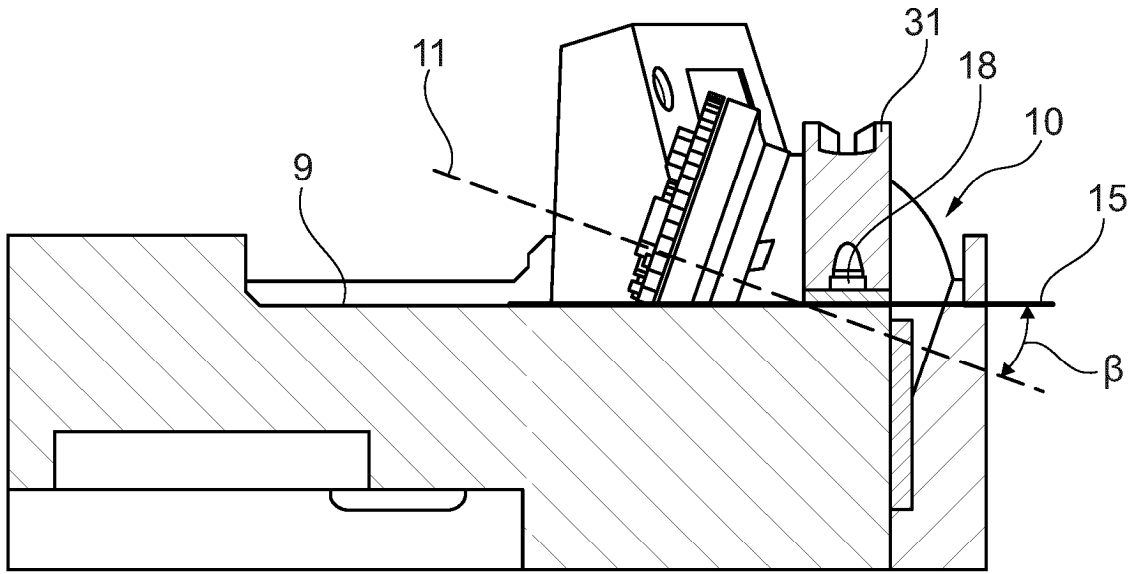

Fig. 16

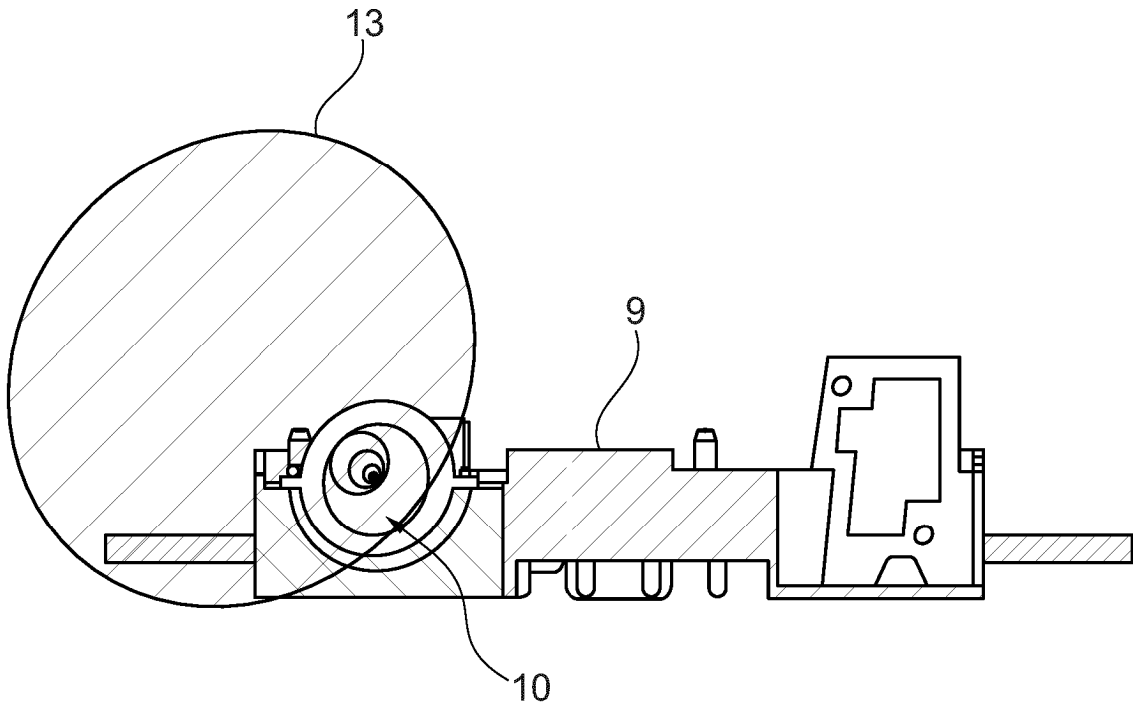

Fig. 17

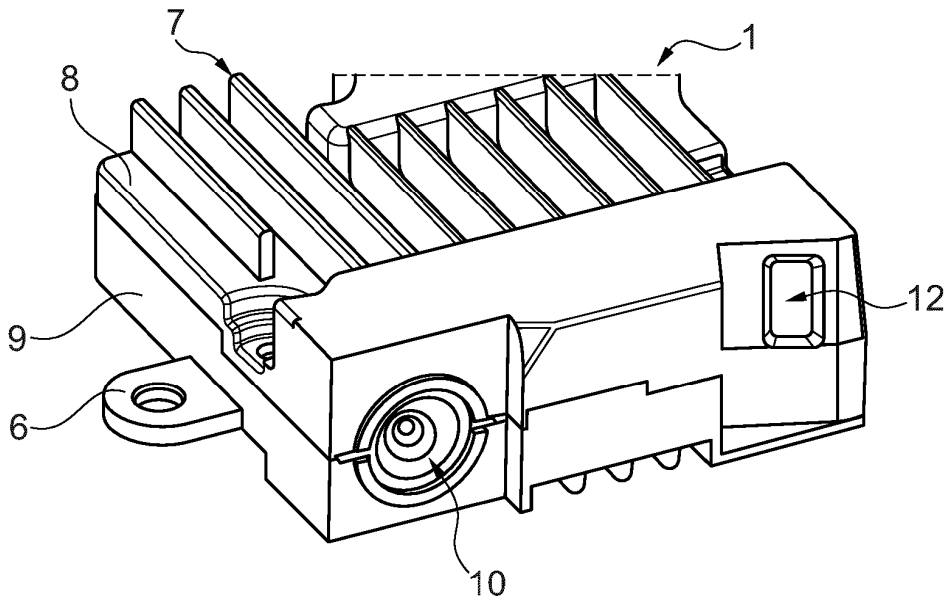

Fig. 18

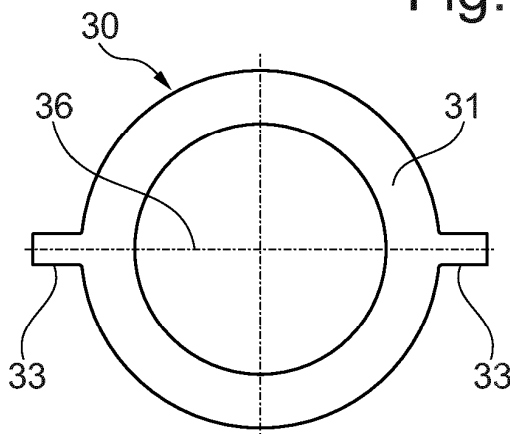

Fig. 19A

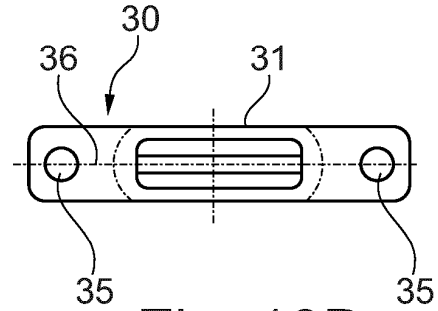

Fig. 19B

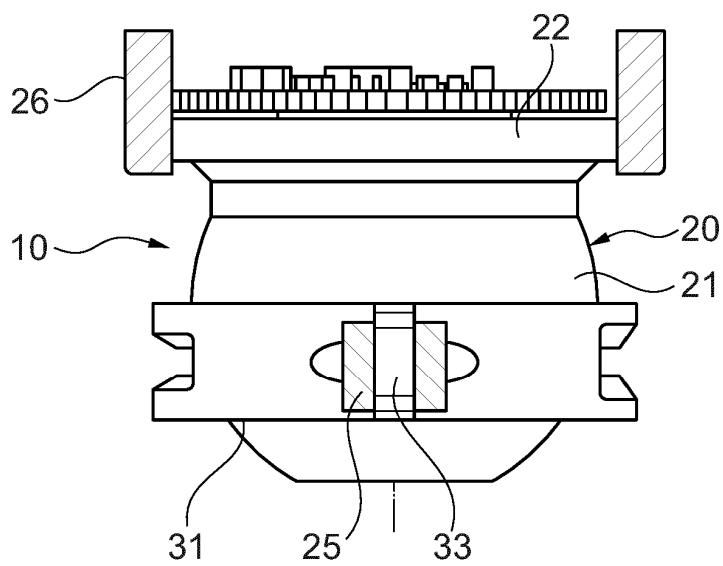

Fig. 20A

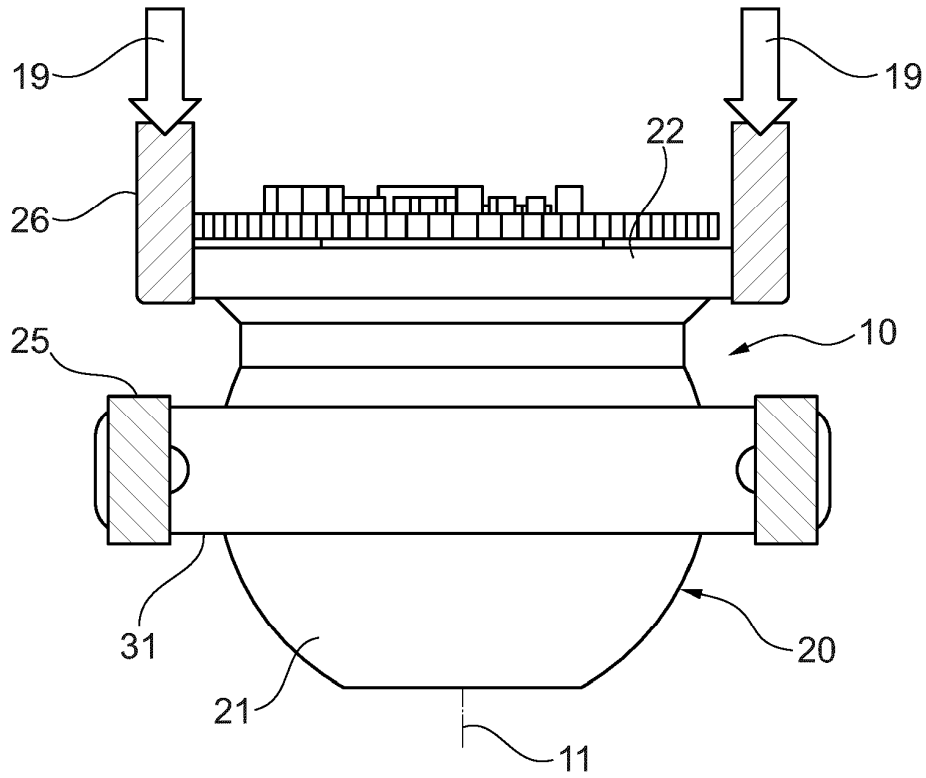

Fig. 20B

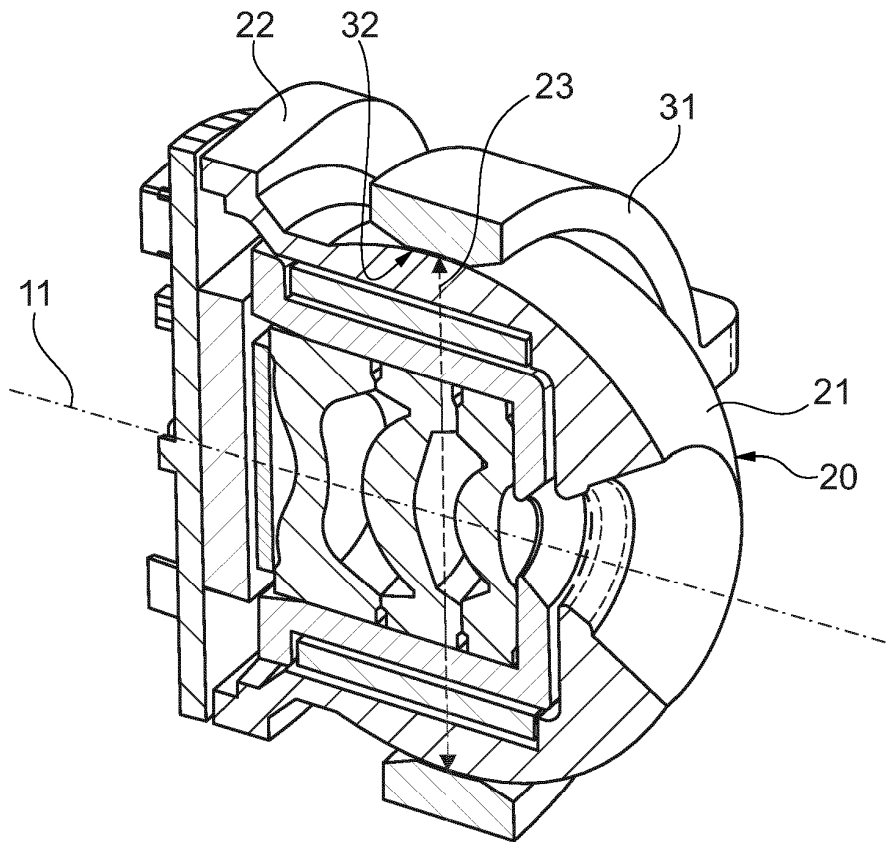
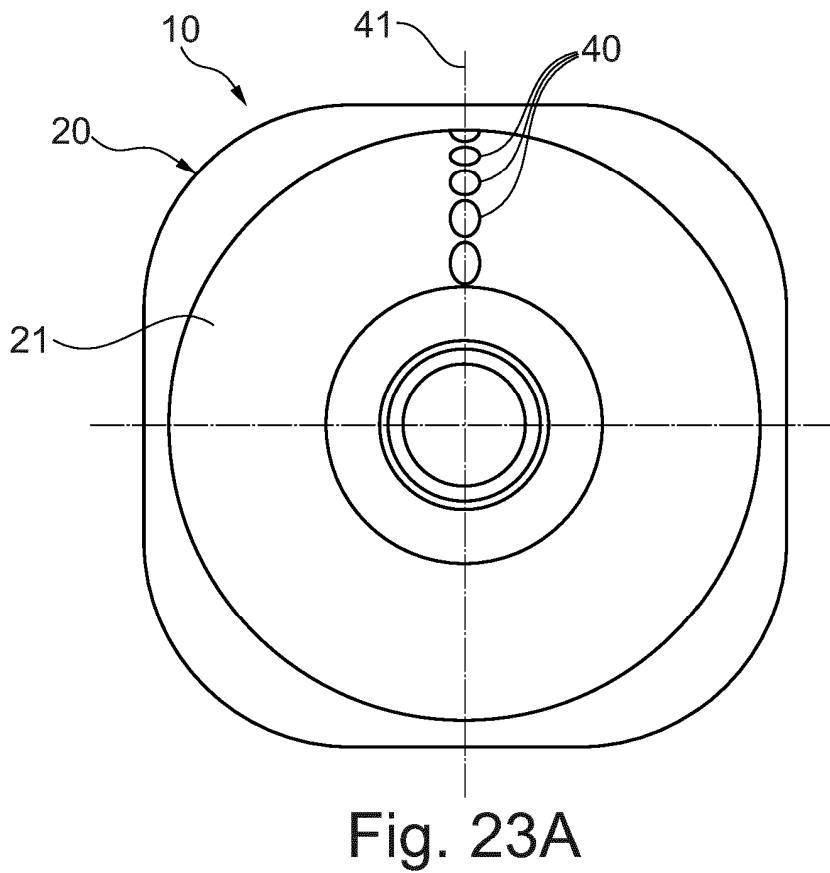
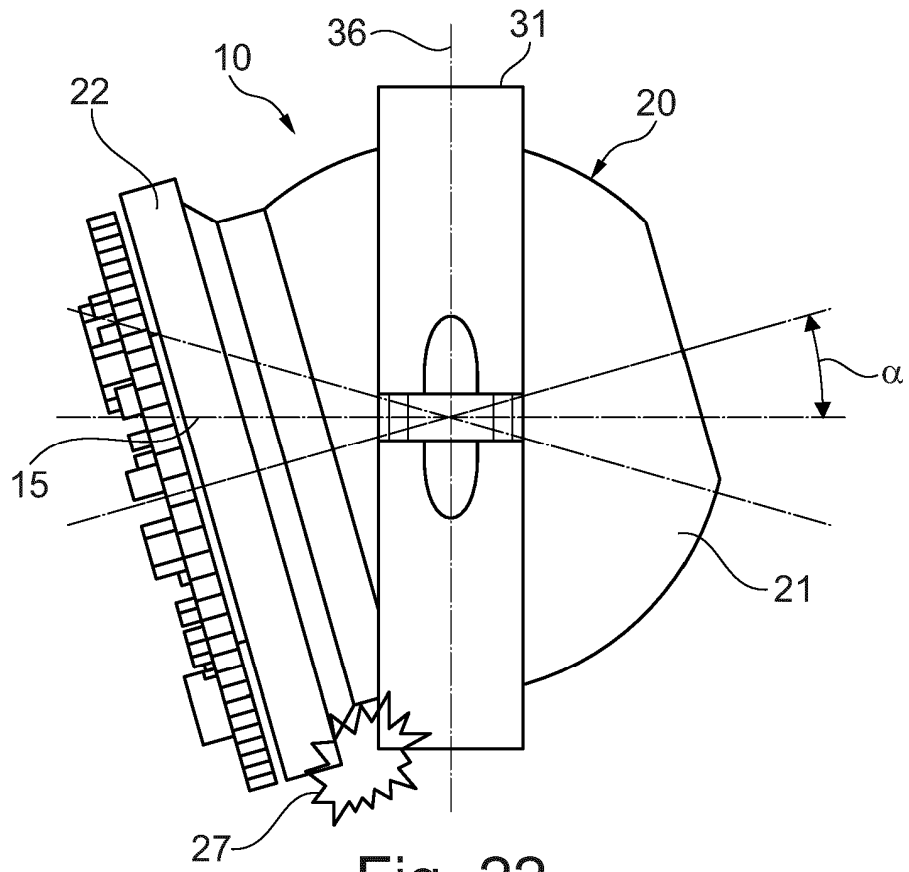

Fig. 21



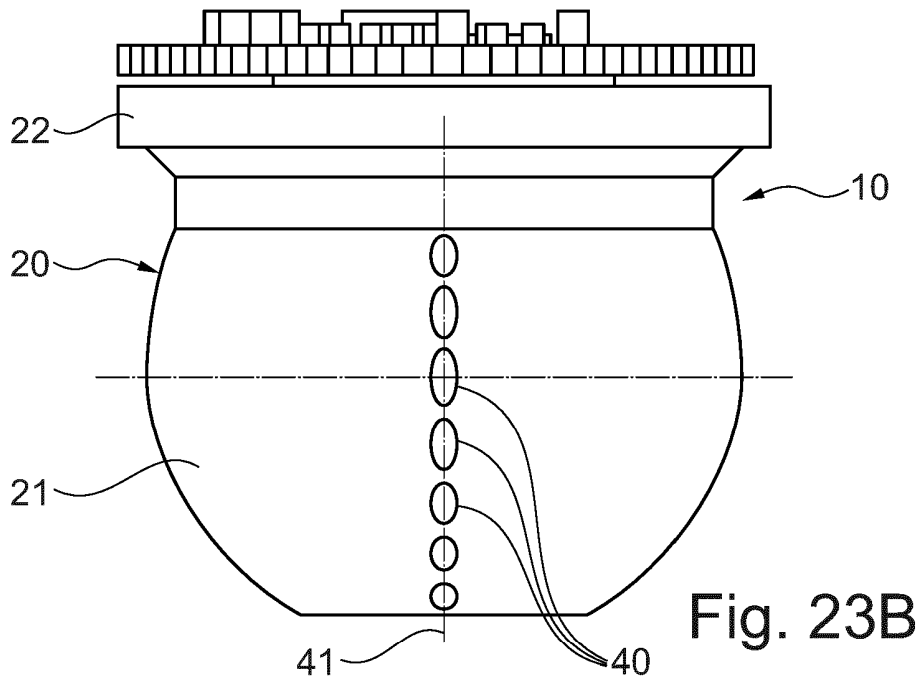

Fig. 23B

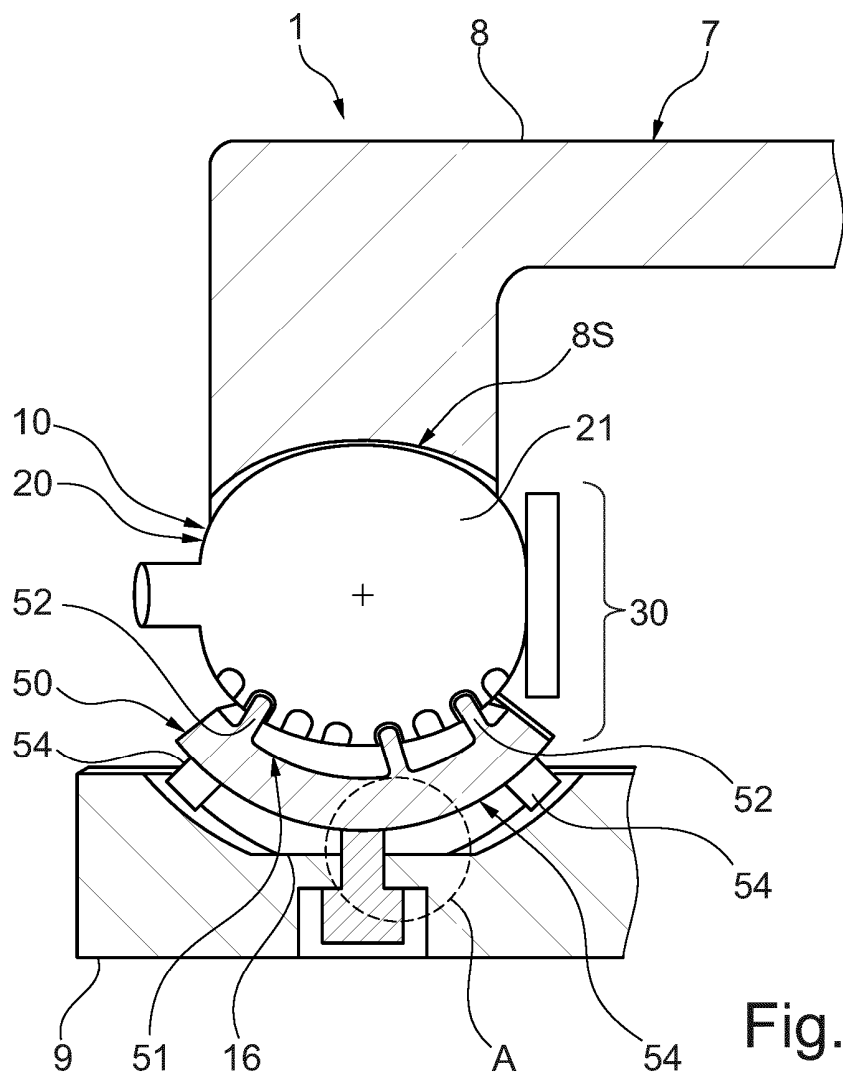

Fig. 24

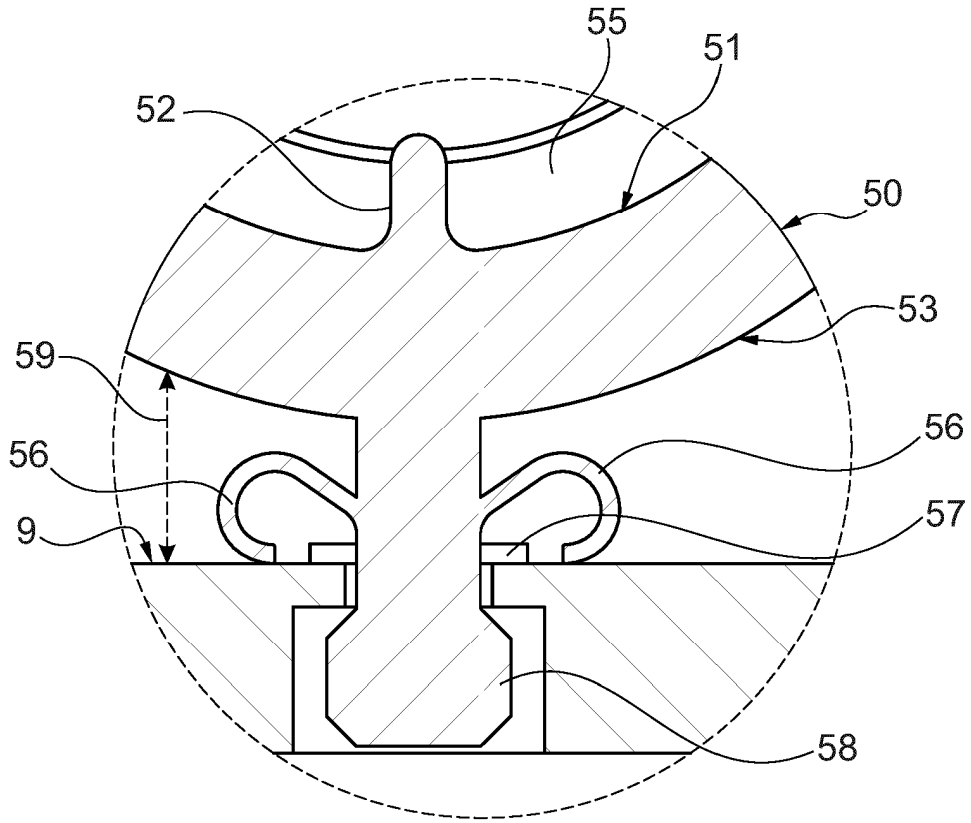

Fig. 25

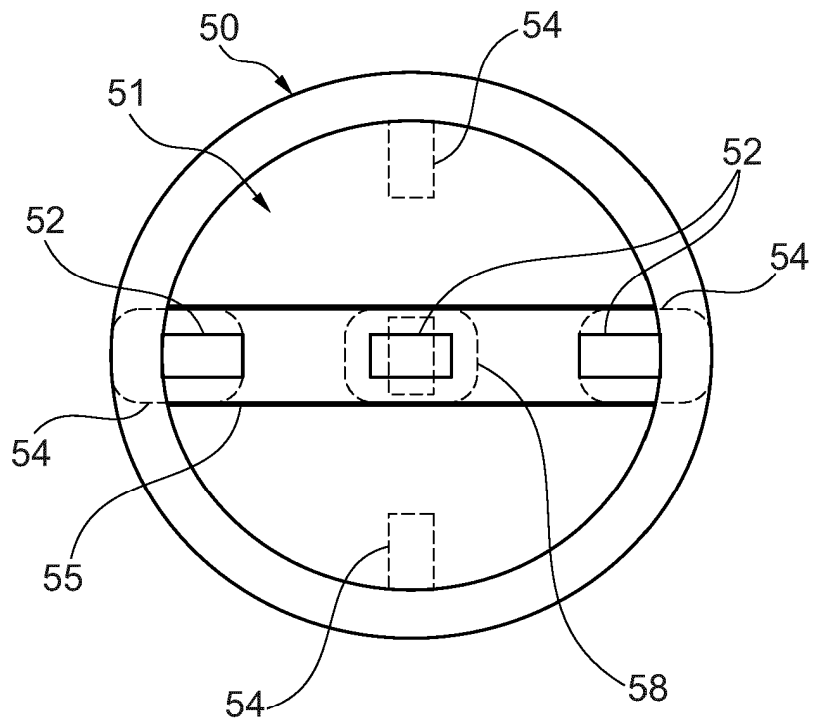

Fig. 26

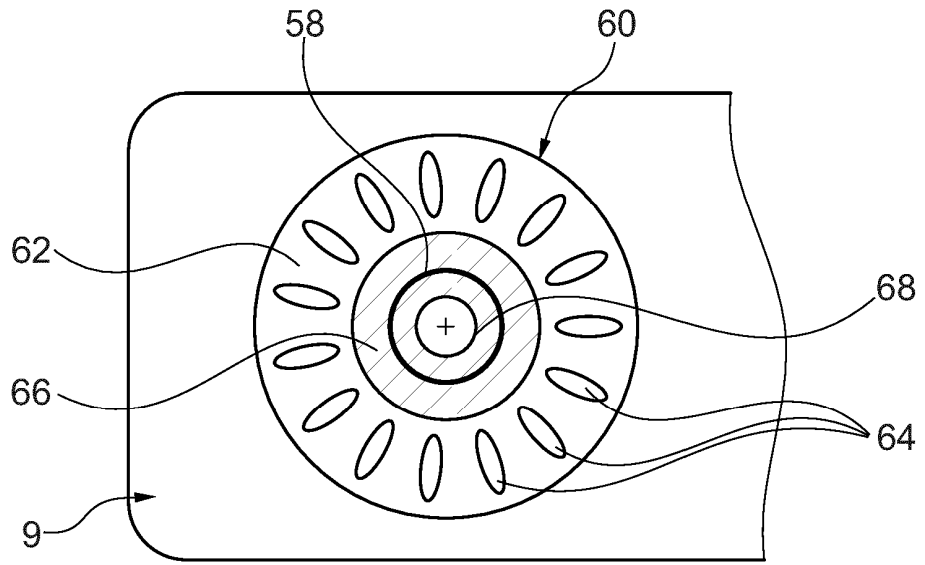

Fig. 27

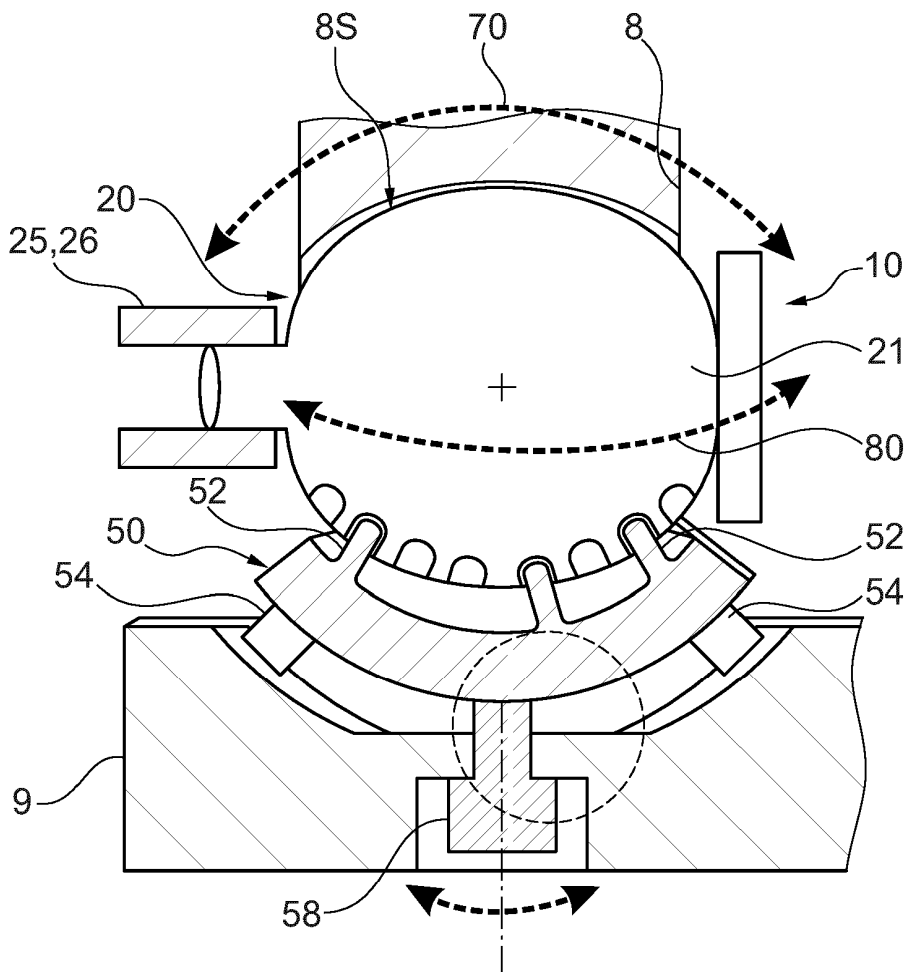

Fig. 28

REFERENCES CITED IN THE DESCRIPTION

This list of references cited by the applicant is for the reader's convenience only. It does not form part of the European patent document. Even though great care has been taken in compiling the references, errors or omissions cannot be excluded and the EPO disclaims all liability in this regard.

Patent documents cited in the description

- WO 2019164724 A1 [0003]
- WO 2018219951 A1 [0004]
- US 2019208091 A1 [0005]
- US 2018222402 A1 [0006]
- CN 203327131 U [0007]
- CN 210016543 U [0008]
- EP 3531685 A1 [0009]
- EP 1469656 A2 [0009]
- US 20200307825 A [0010]